

# Gleason Reel RTG 450 & 700

## I-BEAM FESTOON SYSTEM

FOR RUBBER TIRED AND RAIL MOUNTED GANTRY CRANES

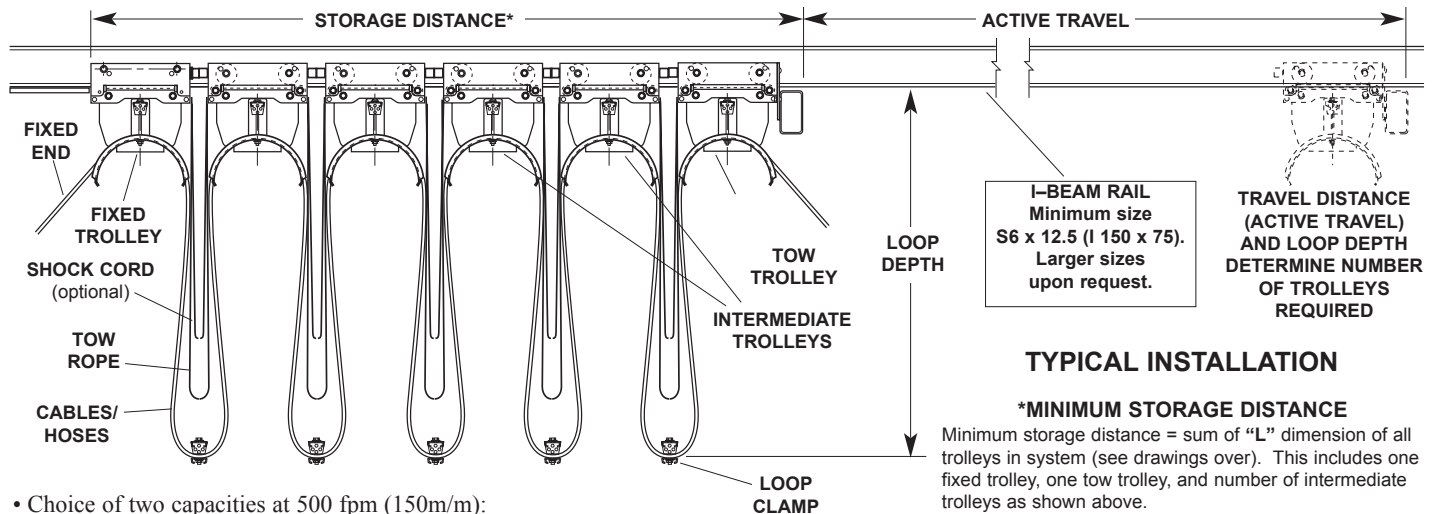

- Choice of two capacities at 500 fpm (150m/m):  
**SERIES RTG-450**, 450 lbs. (202.5kg) capacity per trolley.  
 2.5"(63mm) dia. wheels.  
**SERIES RTG-700**, 700 lbs. (315kg) capacity per trolley.  
 4.0"(102mm) dia. wheels.
- Trolleys ride on four large diameter hardened steel or nylon flanged wheels with oversized sealed ball bearings.
- Four steel anti-lift rollers.
- Key-hole frame design prevents fall if wheels fail.
- Accepts either flat or round cables.
- Dual clamp design (two windows). Rubber compression clamps accommodate a variety of cables.

- Fits S6 X 12.5 or I 150 X 75 beams. Larger sizes on request.
- Choice of three saddle diameters (10.24"[259], 14.12"[359], 18.12"[460]) in two widths: 13.38" (340) and 20.38" (518). Optional double tier saddles also available.
- Fabricated steel construction...no castings.
- Baked polyester or galvanized finish provide superior protection against corrosion.
- Choice of zinc plated or stainless steel hardware.

### ECONOMICALLY PRICED... FILLED WITH OUTSTANDING FEATURES

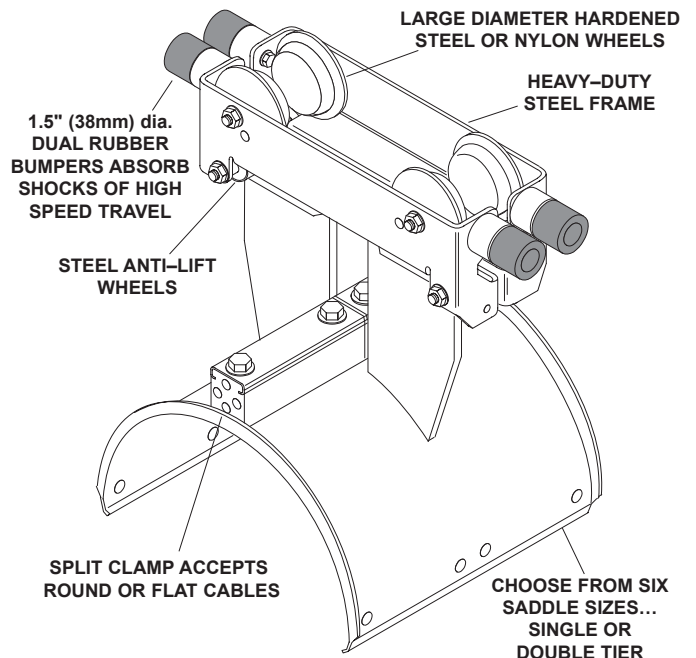
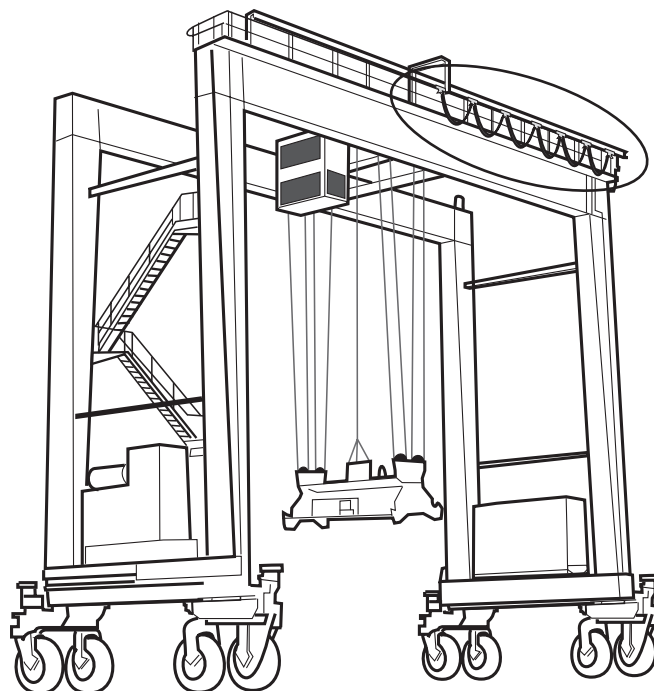

## DIMENSIONS

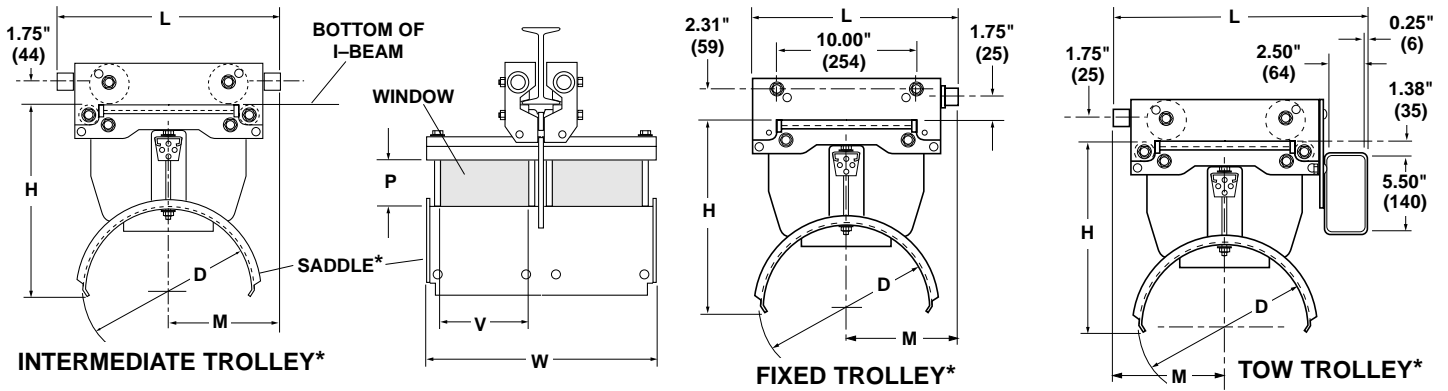

\*Single tier saddles shown. Double tier saddles available. Consult factory.

SERIES 450 MODEL NUMBER	SERIES 700 MODEL NUMBER	"D" SADDLE DIA.	"P" WINDOW HEIGHT	"V" WINDOW WIDTH	"H" BELOW I-BEAM	"L" OVERALL LENGTH	"W" OVERALL WIDTH	"M" SADDLE LOCATOR	WEIGHT lbs.** (kg)
<b>INTERMEDIATE TROLLEY</b>									
RTG-450S-10-0104I-ZP-__	RTG-700S-10-0104I-ZP-__	10.25 (260)	1.38 (35)	4.38(111) 7.88(200)	11.28 (287)	13.88 (353)	13.38(340) 20.38(518)	6.94 (176)	51(23.0) 57(25.7)
RTG-450S-14-0104I-ZP-__	RTG-700S-14-0104I-ZP-__	14.12 (359)	1.44 (37)	4.38(111) 7.88(200)	14.86 (377)	17.88 (454)	13.38(340) 20.38(518)	8.94 (227)	58(26.1) 66(29.7)
RTG-450S-18-0204I-ZP-__	RTG-700S-18-0204I-ZP-__	18.12 (460)	2.00 (51)	4.38(111) 7.88(200)	16.82 (427)	23.00 (584)	13.38(340) 20.38(518)	11.50 (292)	64(28.8) 74(33.3)

### FIXED TROLLEY

First trolley at fixed end of festoon system. Does not have rollers and is bolted in place.

RTG-450S-10-0104F-ZP-__	RTG-700S-10-0104F-ZP-__	10.25 (260)	1.38 (35)	4.38(111) 7.88(200)	12.28 (287)	12.88 (327)	13.38(340) 20.38(518)	6.94 (176)	41(18.5) 47(21.2)
RTG-450S-14-0104F-ZP-__	RTG-700S-14-0104F-ZP-__	14.12 (359)	1.44 (37)	4.38(111) 7.88(200)	14.86 (377)	16.88 (429)	13.38(340) 20.38(518)	8.94 (227)	48(21.6) 56(25.2)
RTG-450S-18-0204F-ZP-__	RTG-700S-18-0204F-ZP-__	18.12 (460)	2.00 (51)	4.38(111) 7.88(200)	16.82 (427)	21.25 (540)	13.38(340) 20.38(518)	11.50 (292)	54(24.3) 64(28.8)

### TOW TROLLEY

Last trolley at moving end of festoon system. One required per system.

RTG-450S-10-0104T-ZP-__	RTG-700S-10-0104T-ZP-__	10.25 (260)	1.38 (35)	4.38(111) 7.88(200)	12.90 (328)	20.13 (511)	13.38(340) 20.38(518)	8.94 (227)	53(23.9) 59(26.6)
RTG-450S-14-0104T-ZP-__	RTG-700S-14-0104T-ZP-__	14.12 (359)	1.44 (37)	4.38(111) 7.88(200)	14.86 (377)	21.19 (538)	13.38(340) 20.38(518)	10.00 (254)	60(27.0) 68(30.6)
RTG-450S-18-0204T-ZP-__	RTG-700S-18-0204T-ZP-__	18.12 (460)	2.00 (51)	4.38(111) 7.88(200)	16.82 (427)	22.87 (581)	13.38(340) 20.38(518)	11.68 (297)	66(29.7) 76(34.2)

\*\*Weight of 700 series. Subtract 10 lbs. for 450 series.

## HOW TO ORDER

Options in model numbers above are shown in **BOLD FACE** below. Substitute letters shown for other desired options.

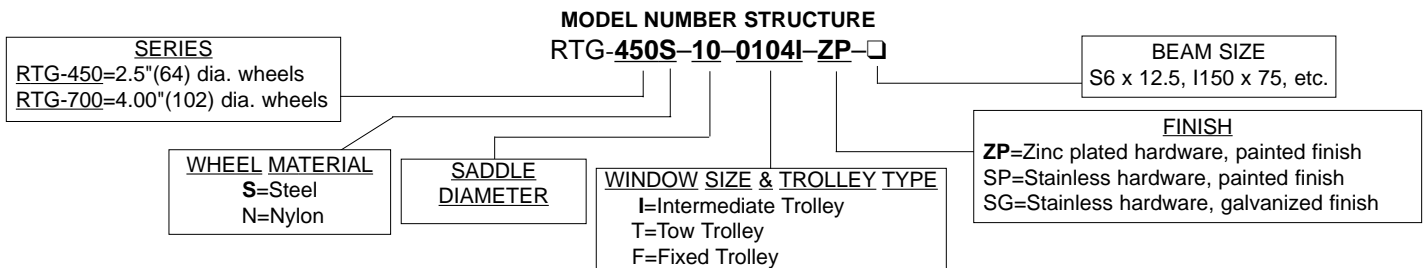

## Gleason Reel Corp.

P.O. Box 26, 600 S. Clark St.  
Mayville, Wisconsin 53050-0026  
Phone 920-387-4120 • FAX 920-387-4189