



# LOW PROFILE LEVEL WIND REELS

Direct replacement for existing low profile reels with up to 100' of cable.  
For magnet or hook/rotate applications.  
From the leader in cable reels.



- Fit in the same space as existing low profile reels. Handle same sizes and lengths of cable.
- Offer features not available on comparable low profile reels.
- Externally mounted springs can be easily adjusted or replaced.
- Parallel spring design provides greater application flexibility. Winding tension is tailored to your needs by increasing or decreasing number of springs and by easy spring adjustment.
- Level wind roller eliminates cable “pile-up” on spool.
- Standard 35, 75, 125 or 200 amp collectors used.

## Unique design...easily configured to your specific application

The low profile reels on many cranes and other equipment designed to use such reels are getting old. Many can no longer be repaired and must be replaced. To fill the need for these replacement reels, Gleason Reel has introduced the **Low Profile Level Wind Reel**, designed to fit in the same space and handle the same cable as the existing reels.

These new reels incorporate standard components used in thousands of Gleason reels throughout the world. The drive springs, electrical collector and its housing, as well as most frame and spool parts are standard. To make the reel fit exist-

ing spaces, Gleason engineers arranged the components with the collector inside the spool and the spring on the outside. There is no need to disconnect cable or disassemble the reel to adjust or replace the spring.

**Another Gleason exclusive.** On multiple spring reels, springs are linked in parallel, not in series. This feature provides three distinct benefits: First, all springs are easily adjusted from one point. Second, rewind torque can be easily tailored to fit application requirements. Third, should one spring fail, the other springs remain engaged and tension is maintained on the cable.



**Externally mounted springs may be easily adjusted or replaced without disconnecting cable or disassembling reel.**

**TYPICAL DIMENSIONS—Reel to handle 60' of #10/4 conductor cable, hook/rotate application.**

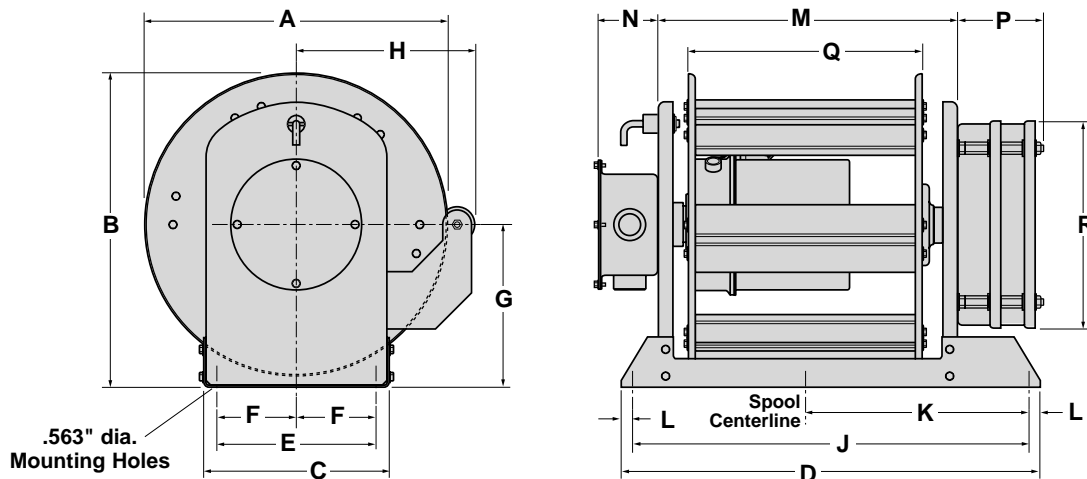

A	B	C	D	E	F	G	H	J	K	L	M	N	P	Q	R
21.00	21.75	12.86	29.00	11.00	5.50	11.25	12.38	27.50	15.53	.75	20.72	4.00	5.98	16.00	14.34



### Gleason Reel Corp.

600 South Clark Street • P.O. Box 26  
 Mayville, WI 53050  
 Phone: 920-387-4120 • Fax: 920-387-4189  
[www.gleasonreel.com](http://www.gleasonreel.com)