

Direct Crank–Electric Motor–Portable Reels

High pressure spray reels

MAX. OPERATING PRESSURE 3000 P.S.I.

ORDERING—Please supply the following information.
 1—Top or bottom wind. 4—Model number of reel.
 2—Right of left hand inlet. 5—Type of rim.
 3—Product to be handled.



DIRECT CRANK ON CENTER SHAFT

MODEL NUMBER	HOSE			DIMENSIONS IN INCHES						
	L	ID	OD	A	B	C	D	E	F	G
HD1809-08	100'	1/2"	1"	18"	19-1/2"	9"	11"	19-5/8"	12"	15-7/8"
HD1809-06	175'	3/8"	3/4"	18"	19-1/2"	9"	11"	19-5/8"	12"	15-7/8"
HD2012-08	200'	1/2"	1"	20"	21-1/2"	12"	11"	22-5/8"	12"	18-7/8"
HD2012-06	300'	3/8"	3/4"	20"	21-1/2"	12"	11"	22-5/8"	12"	18-7/8"
HD2214-08	300'	1/2"	1"	22"	23-1/2"	14"	11"	24-5/8"	12"	20-7/8"
HD2214-06	500'	3/8"	3/4"	22"	23-1/2"	14"	11"	24-5/8"	12"	20-7/8"
HD2515-08	400'	1/2"	1"	25"	26-1/2"	15"	11"	25-5/8"	12"	21-7/8"
HD2515-06	800'	3/8"	3/4"	25"	26-1/2"	15"	11"	25-5/8"	12"	21-7/8"

Approximate Net Weight-45 lbs.

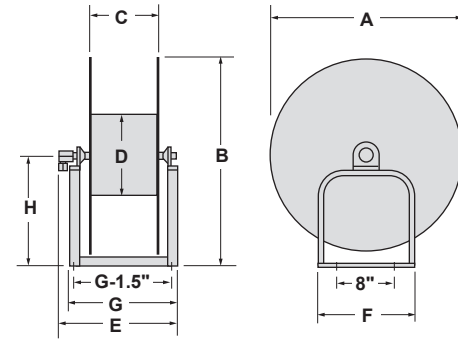

12 VOLT ELECTRIC MOTOR DRIVE

MODEL NUMBER	HOSE			DIMENSIONS IN INCHES						
	L	ID	OD	A	B	C	D	E	F	G
HE1809-08	100'	1/2"	1"	18"	20-1/2"	9"	11"	24-3/8"	20"	15-7/8"
HE1809-06	175'	3/8"	3/4"	18"	20-1/2"	9"	11"	24-3/8"	20"	15-7/8"
HE2012-08	200'	1/2"	1"	20"	21-1/2"	12"	11"	27-3/8"	20"	18-7/8"
HE2012-06	300'	3/8"	3/4"	20"	21-1/2"	12"	11"	27-3/8"	20"	18-7/8"
HE2214-08	300'	1/2"	1"	22"	23-1/2"	14"	11"	29-3/8"	20"	20-7/8"
HE2214-06	500'	3/8"	3/4"	22"	23-1/2"	14"	11"	29-3/8"	20"	20-7/8"
HE2515-08	400'	1/2"	1"	25"	26-1/2"	15"	11"	30-3/8"	20"	21-7/8"
HE2515-06	800'	3/8"	3/4"	25"	26-1/2"	15"	11"	30-3/8"	20"	21-7/8"

Approximate Net Weight-100 lbs.

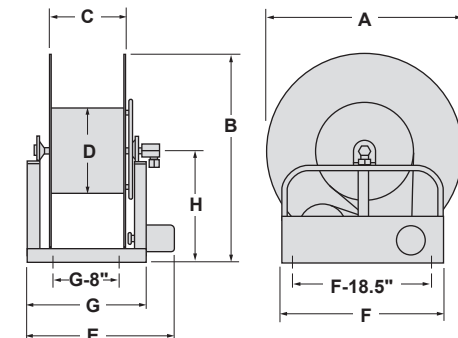

PORTABLE REELS

MODEL NUMBER	HOSE			DIMENSIONS IN INCHES							No. LAYERS
	L	ID	A	B	C	D	E	F	G	H	
HP2018-12	100'	3/4"	20"	42"	18"	11"	30-3/4"	12"	24-7/8"	11-1/2"	3
HP2213-12	100'	3/4"	22"	42"	13"	11"	25-3/4"	12"	19-7/8"	12-1/2"	4
HP2511-12	100'	3/4"	25"	42"	11"	11"	23-3/4"	12"	17-7/8"	14"	5
HP2023-12	150'	3/4"	20"	42"	23"	11"	35-3/4"	12"	29-7/8"	11-1/2"	3
HP2218-12	150'	3/4"	22"	42"	18"	11"	30-3/4"	12"	24-7/8"	12-1/2"	4
HP2515-12	150'	3/4"	25"	42"	15"	11"	27-3/4"	12"	21-7/8"	14"	5
HP2223-12	200'	3/4"	22"	42"	23"	11"	35-3/4"	12"	29-7/8"	12-1/2"	4
HP2518-12	200'	3/4"	25"	42"	18"	11"	30-3/4"	12"	24-7/8"	14"	5
HP2815-12	200'	3/4"	28"	42"	15"	11"	27-3/4"	12"	21-7/8"	15-1/2"	6

Approximate Net Weight-70 lbs.

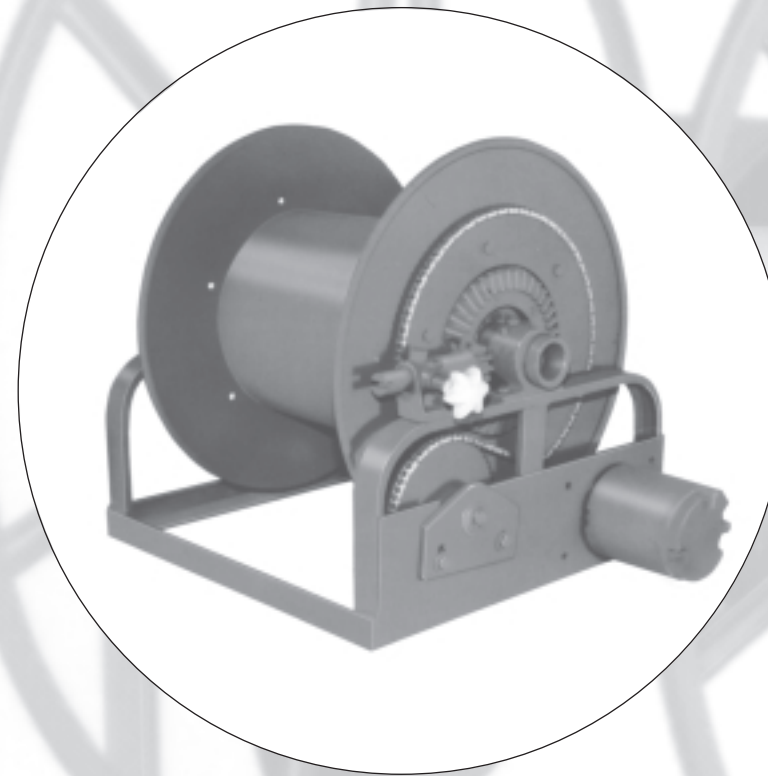
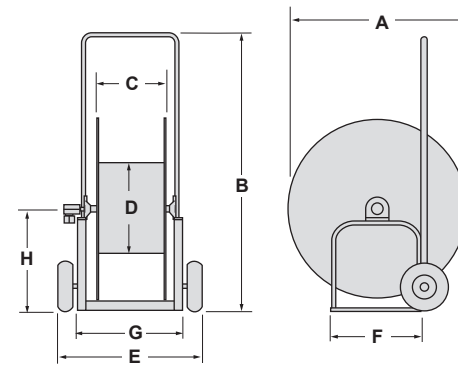

GLEASON HAND AND POWER DRIVEN HOSE REELS

Spec-Tech Industrial Electric

Toll Free: (888) SPECTECH (773-2832)
 Fax: (636) 537-1405
 Email: sales@spectechind.com
 Address: 203 Vest Avenue
 Valley Park, MO 63088

Rim Rewind

Hand operated reels are of all steel construction. Available with solid or spoke type rim. Reels as listed are good for pressures up to 600 P.S.I. Contact factory for higher pressures.



Crank Rewind

Crank operated reels are supplied with a 4 to 1 ratio bevel gear drive and brake. Available with solid or spoke type rim. Reels as listed are rated for pressures up to 600 P.S.I. Contact factory for higher pressures.

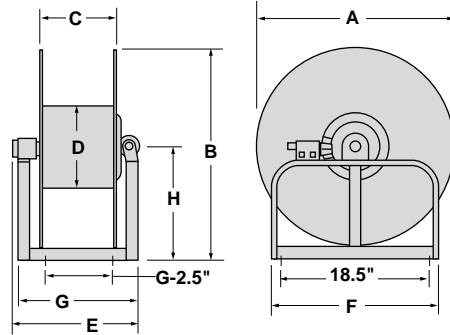
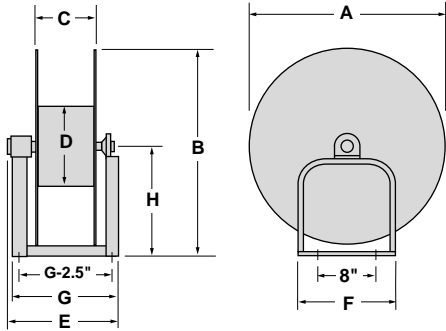

MODEL NO.	HOSE			DIMENSIONS IN INCHES								No. LAYERS
	L	ID	OD	A	B	C	D	E	F	G	H	
1812-16	50'	1	1-9/16	18	20-1/2	12	11	26	20	19	11-1/2	2
2009-16	50'	1	1-9/16	20	21-1/2	9	11	23	20	16	11-1/2	3
2206-16	50'	1	1-9/16	22	23-1/2	6	11	20	20	13	12-1/2	4
2505-16	50'	1	1-9/16	25	26-1/2	5	11	19	20	12	14	5
2804-16	50'	1	1-9/16	28	29-1/2	4	11	18	20	11	15-1/2	6
1823-16	100'	1	1-9/16	18	20-1/2	23	11	37	20	30	11-1/2	2
2015-16	100'	1	1-9/16	20	21-1/2	15	11	29	20	22	11-1/2	3
2212-16	100'	1	1-9/16	22	23-1/2	12	11	26	20	19	12-1/2	4
2508-16	100'	1	1-9/16	25	26-1/2	8	11	22	20	15	14	5
2807-16	100'	1	1-9/16	28	29-1/2	7	11	21	20	14	15-1/2	6
1833-16	150'	1	1-9/16	18	20-1/2	33	11	47	20	40	11-1/2	2
2022-16	150'	1	1-9/16	20	21-1/2	22	11	36	20	29	11-1/2	3
2215-16	150'	1	1-9/16	22	23-1/2	15	11	29	20	22	12-1/2	4
2512-16	150'	1	1-9/16	25	26-1/2	12	11	26	20	19	14	5
2810-16	150'	1	1-9/16	28	29-1/2	10	11	24	20	17	15-1/2	6
1844-16	200'	1	1-9/16	18	20-1/2	44	11	58	20	51	11-1/2	2
2029-16	200'	1	1-9/16	20	21-1/2	29	11	43	20	36	11-1/2	3
2220-16	200'	1	1-9/16	22	23-1/2	20	11	34	20	27	12-1/2	4
2515-16	200'	1	1-9/16	25	26-1/2	15	11	29	20	22	14	5
2812-16	200'	1	1-9/16	28	29-1/2	12	11	26	20	19	15-1/2	6
1821-16	75'	1-1/4	1-7/8	18	20-1/2	21	11	35	20	28	11-1/2	2
2214-16	75'	1-1/4	1-7/8	22	23-1/2	14	11	28	20	21	12-1/2	3
2510-16	75'	1-1/4	1-7/8	25	26-1/2	10	11	24	20	17	14	4
1828-16	100'	1-1/4	1-7/8	18	20-1/2	28	11	42	20	35	11-1/2	2
2217-16	100'	1-1/4	1-7/8	22	23-1/2	17	11	31	20	24	12-1/2	3
2514-16	100'	1-1/4	1-7/8	25	26-1/2	14	11	28	20	21	14	4

MODEL NO.	HOSE			DIMENSIONS IN INCHES								No. LAYERS
	L	ID	OD	A	B	C	D	E	F	G	H	
1832-20	125'	1-1/4	1-7/8	18	20-1/2	32	11	46	20	39	11-1/2	2
2221-20	125'	1-1/4	1-7/8	22	23-1/2	21	11	35	20	28	12-1/2	3
2516-20	125'	1-1/4	1-7/8	25	26-1/2	16	11	30	20	23	14	4
2016-24	50'	1-1/2	2	20	21-1/2	16	11	30	20	23	11-1/2	2
2210-24	50'	1-1/2	2	22	23-1/2	10	11	24	20	17	12-1/2	3
2808-24	50'	1-1/2	2	28	29-1/2	8	11	22	20	15	15-1/2	4
2029-24	100'	1-1/2	2	20	21-1/2	29	11	43	20	36	11-1/2	2
2220-24	100'	1-1/2	2	22	23-1/2	20	11	34	20	27	12-1/2	3
2814-24	100'	1-1/2	2	28	29-1/2	14	11	28	20	21	15-1/2	4
2042-24	150'	1-1/2	2	20	21-1/2	42	11	56	20	49	11-1/2	2
2226-24	150'	1-1/2	2	22	23-1/2	26	11	40	20	33	12-1/2	3
2819-24	150'	1-1/2	2	28	29-1/2	19	11	33	20	26	15-1/2	6
2055-24	200'	1-1/2	2	20	21-1/2	55	11	69	20	62	11-1/2	2
2234-24	200'	1-1/2	2	22	23-1/2	34	11	48	20	41	12-1/2	3
2825-24	200'	1-1/2	2	28	29-1/2	25	11	39	20	32	15-1/2	4
2230-32	50'	2	2-1/2	22	23-1/2	30	16	44	20	37	12-1/2	1
2816-32	50'	2	2-1/2	28	29-1/2	16	16	30	20	23	15-1/2	2
3211-32	50'	2	2-1/2	32	33-1/2	11	16	25	20	18	17-1/2	3
2829-32	100'	2	2-1/2	28	29-1/2	29	16	43	20	36	15-1/2	2
3219-32	100'	2	2-1/2	32	33-1/2	19	16	33	25	26	17-1/2	3
3227-32	150'	2	2-1/2	32	33-1/2	27	16	41	25	34	17-1/2	3
3418-48	50'	3	3-1/2	34	36	18	20	32	25	25	19	2
3432-48	100'	3	3-1/2	34	36	32	20	46	25	39	19	2

Approximate net weight: Rim Wind-65 lbs.
Gear Crank-70 lbs.

ORDERING—Please supply the following information.

- 1—Top or bottom wind.
- 2—Right or left hand inlet.
- 3—Straight or elbow type joint.
- 4—Product to be handled.
- 5—Model number of reel.
- 6—Type of rim.
- 7—Right or left hand crank.
- 8—Use prefix **HR** for Rim Rewind
Use prefix **HG** for Crank Rewind.

Air Motor Rewind



Top Wind
L.H. Inlet
Straight Type Joint
Spoke Rim

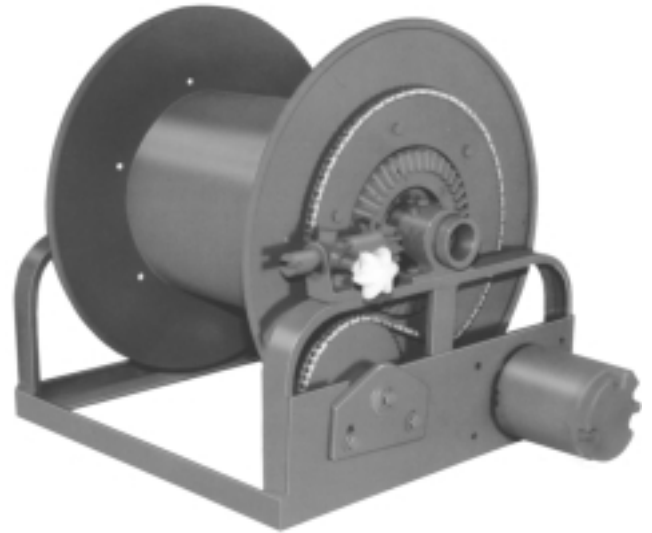

Top Wind
R.H. Inlet
Straight Joint
Solid Rim

Electric Motor Rewind

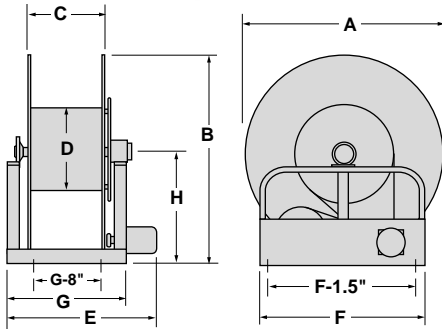

STANDARD EQUIPMENT

- Auxiliary crank
- Slow Speed Reduction
- 600 P.S.I. Swivel Joint (straight)
- Control Valve, Filter and Lubricator (Air only)
- Switch, Solenoid, Circuit Breaker (12v only)

OPTIONAL EQUIPMENT

- Automatic Air Clutch (Air only)
- High Pressure Swivel Joints (elbow)
- Automatic Electric Clutch
- Roller Guide
- Explosion Proof Motor

NOTE: For Air Motor Drive deduct 3" from "E" dimension

MODEL NO.	HOSE			DIMENSIONS IN INCHES								No. LAYERS
	L	ID	OD	A	B	C	D	E	F	G	H	
1812-16	50'	1	1-9/16	18	19-1/2	12	11	20	12	19	10-1/2	2
2009-16	50'	1	1-9/16	20	21-1/2	9	11	17	12	16	11-1/2	3
2206-16	50'	1	1-9/16	22	23-1/2	6	11	14	12	13	12-1/2	4
2505-16	50'	1	1-9/16	25	26-1/2	5	11	13	12	12	14	5
2804-16	50'	1	1-9/16	28	29-1/2	4	11	12	12	11	15-1/2	6
1823-16	100'	1	1-9/16	18	19-1/2	23	11	31	12	30	10-1/2	2
2015-16	100'	1	1-9/16	20	21-1/2	15	11	23	12	22	11-1/2	3
2212-16	100'	1	1-9/16	22	23-1/2	12	11	20	12	19	12-1/2	4
2508-16	100'	1	1-9/16	25	26-1/2	8	11	16	12	15	14	5
2807-16	100'	1	1-9/16	28	29-1/2	7	11	15	12	14	15-1/2	6
1833-16	150'	1	1-9/16	18	19-1/2	33	11	41	12	40	10-1/2	2
2022-16	150'	1	1-9/16	20	21-1/2	22	11	30	12	29	11-1/2	3
2215-16	150'	1	1-9/16	22	23-1/2	15	11	23	12	22	12-1/2	4
2512-16	150'	1	1-9/16	25	26-1/2	12	11	20	12	19	14	5
2810-16	150'	1	1-9/16	28	29-1/2	10	11	18	12	17	15-1/2	6
1844-16	200'	1	1-9/16	18	19-1/2	44	11	52	12	51	10-1/2	2
2029-16	200'	1	1-9/16	20	21-1/2	29	11	37	12	36	11-1/2	3
2220-16	200'	1	1-9/16	22	23-1/2	20	11	28	12	27	12-1/2	4
2515-16	200'	1	1-9/16	25	26-1/2	15	11	23	12	22	14	5
2812-16	200'	1	1-9/16	28	29-1/2	12	11	20	12	19	15-1/2	6
1821-16	75'	1-1/4	1-7/8	18	19-1/2	21	11	29	12	28	10-1/2	2
2214-16	75'	1-1/4	1-7/8	22	23-1/2	14	11	22	12	21	12-1/2	3
2510-16	75'	1-1/4	1-7/8	25	26-1/2	10	11	18	12	17	14	4
1828-16	100'	1-1/4	1-7/8	18	19-1/2	28	11	36	12	35	10-1/2	2
2217-16	100'	1-1/4	1-7/8	22	23-1/2	17	11	25	12	24	12-1/2	3
2514-16	100'	1-1/4	1-7/8	25	26-1/2	14	11	22	12	21	14	4

MODEL NO.	HOSE			DIMENSIONS IN INCHES								No. LAYERS
	L	ID	OD	A	B	C	D	E	F	G	H	
1832-20	125'	1-1/4	1-7/8	18	19-1/2	32	11	40	12	39	10-1/2	2
2221-20	125'	1-1/4	1-7/8	22	23-1/2	21	11	29	12	28	12-1/2	3
2516-20	125'	1-1/4	1-7/8	25	26-1/2	16	11	24	12	23	14	4
2016-24	50'	1-1/2	2	20	21-1/2	16	11	24	12	23	11-1/2	2
2210-24	50'	1-1/2	2	22	23-1/2	10	11	18	12	17	12-1/2	3
2808-24	50'	1-1/2	2	28	29-1/2	8	11	16	12	15	15-1/2	4
2029-24	100'	1-1/2	2	20	21-1/2	29	11	37	12	36	11-1/2	2
2220-24	100'	1-1/2	2	22	23-1/2	20	11	28	12	27	12-1/2	3
2814-24	100'	1-1/2	2	28	29-1/2	14	11	22	12	21	15-1/2	4
2042-24	150'	1-1/2	2	20	21-1/2	42	11	50	12	49	11-1/2	2
2226-24	150'	1-1/2	2	22	23-1/2	26	11	34	12	33	12-1/2	3
2819-24	150'	1-1/2	2	28	29-1/2	19	11	27	12	26	15-1/2	6
2055-24	200'	1-1/2	2	20	21-1/2	55	11	63	12	62	11-1/2	2
2234-24	200'	1-1/2	2	22	23-1/2	34	11	42	12	41	12-1/2	3
2825-24	200'	1-1/2	2	28	29-1/2	25	11	33	12	32	15-1/2	4
2230-32	50'	2	2-1/2	22	23-1/2	30	16	38	12	37	12-1/2	1
2816-32	50'	2	2-1/2	28	29-1/2	16	16	24	12	23	15-1/2	2
3211-32	50'	2	2-1/2	32	33-1/2	11	16	19	12	18	17-1/2	3
2829-32	100'	2	2-1/2	28	29-1/2	29	16	37	12	36	15-1/2	2
3219-32	100'	2	2-1/2	32	33-1/2	19	16	27	12	26	17-1/2	3
3227-32	150'	2	2-1/2	32	33-1/2	27	16	35	12	34	17-1/2	3
3418-48	50'	3	3-1/2	34	36	18	20	26	12	25	19	2
3432-48	100'	3	3-1/2	34	36	32	20	40	12	39	19	2

Approximate net weight: Air Motor-95 lbs.
Electric Motor-115 lbs.

ORDERING—Please supply the following information.

- 1—Top or bottom wind.
- 2—Right or left hand inlet.
- 3—Straight or elbow type joint.
- 4—Product to be handled.
- 5—Model number of reel.
- 6—Type of Rim
- 7—Use prefix **HA** for Air Motor Drive.
Use prefix **HE** for Electric Motor Drive.
- 8—115 Volt Totally Enclosed.
12 Volt D.C. Standard.
12 Volt Explosion-Proof.
Class I, Group D.

Direct Crank–Electric Motor–Portable Reels

High pressure spray reels

MAX. OPERATING PRESSURE 3000 P.S.I.

ORDERING—Please supply the following information.
 1—Top or bottom wind. 4—Model number of reel.
 2—Right of left hand inlet. 5—Type of rim.
 3—Product to be handled.



DIRECT CRANK ON CENTER SHAFT

MODEL NUMBER	HOSE			DIMENSIONS IN INCHES						
	L	ID	OD	A	B	C	D	E	F	G
HD1809-08	100'	1/2"	1"	18"	19-1/2"	9"	11"	19-5/8"	12"	15-7/8"
HD1809-06	175'	3/8"	3/4"	18"	19-1/2"	9"	11"	19-5/8"	12"	15-7/8"
HD2012-08	200'	1/2"	1"	20"	21-1/2"	12"	11"	22-5/8"	12"	18-7/8"
HD2012-06	300'	3/8"	3/4"	20"	21-1/2"	12"	11"	22-5/8"	12"	18-7/8"
HD2214-08	300'	1/2"	1"	22"	23-1/2"	14"	11"	24-5/8"	12"	20-7/8"
HD2214-06	500'	3/8"	3/4"	22"	23-1/2"	14"	11"	24-5/8"	12"	20-7/8"
HD2515-08	400'	1/2"	1"	25"	26-1/2"	15"	11"	25-5/8"	12"	21-7/8"
HD2515-06	800'	3/8"	3/4"	25"	26-1/2"	15"	11"	25-5/8"	12"	21-7/8"

Approximate Net Weight-45 lbs.

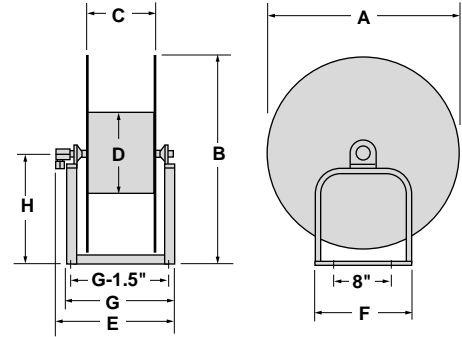

12 VOLT ELECTRIC MOTOR DRIVE

MODEL NUMBER	HOSE			DIMENSIONS IN INCHES						
	L	ID	OD	A	B	C	D	E	F	G
HE1809-08	100'	1/2"	1"	18"	20-1/2"	9"	11"	24-3/8"	20"	15-7/8"
HE1809-06	175'	3/8"	3/4"	18"	20-1/2"	9"	11"	24-3/8"	20"	15-7/8"
HE2012-08	200'	1/2"	1"	20"	21-1/2"	12"	11"	27-3/8"	20"	18-7/8"
HE2012-06	300'	3/8"	3/4"	20"	21-1/2"	12"	11"	27-3/8"	20"	18-7/8"
HE2214-08	300'	1/2"	1"	22"	23-1/2"	14"	11"	29-3/8"	20"	20-7/8"
HE2214-06	500'	3/8"	3/4"	22"	23-1/2"	14"	11"	29-3/8"	20"	20-7/8"
HE2515-08	400'	1/2"	1"	25"	26-1/2"	15"	11"	30-3/8"	20"	21-7/8"
HE2515-06	800'	3/8"	3/4"	25"	26-1/2"	15"	11"	30-3/8"	20"	21-7/8"

Approximate Net Weight-100 lbs.

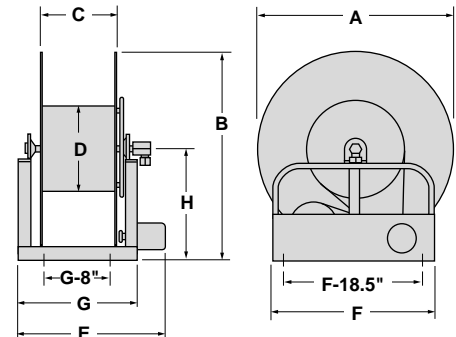

PORTABLE REELS

MODEL NUMBER	HOSE			DIMENSIONS IN INCHES							No. LAYERS
	L	ID	A	B	C	D	E	F	G	H	
HP2018-12	100'	3/4"	20"	42"	18"	11"	30-3/4"	12"	24-7/8"	11-1/2"	3
HP2213-12	100'	3/4"	22"	42"	13"	11"	25-3/4"	12"	19-7/8"	12-1/2"	4
HP2511-12	100'	3/4"	25"	42"	11"	11"	23-3/4"	12"	17-7/8"	14"	5
HP2023-12	150'	3/4"	20"	42"	23"	11"	35-3/4"	12"	29-7/8"	11-1/2"	3
HP2218-12	150'	3/4"	22"	42"	18"	11"	30-3/4"	12"	24-7/8"	12-1/2"	4
HP2515-12	150'	3/4"	25"	42"	15"	11"	27-3/4"	12"	21-7/8"	14"	5
HP2223-12	200'	3/4"	22"	42"	23"	11"	35-3/4"	12"	29-7/8"	12-1/2"	4
HP2518-12	200'	3/4"	25"	42"	18"	11"	30-3/4"	12"	24-7/8"	14"	5
HP2815-12	200'	3/4"	28"	42"	15"	11"	27-3/4"	12"	21-7/8"	15-1/2"	6

Approximate Net Weight-70 lbs.

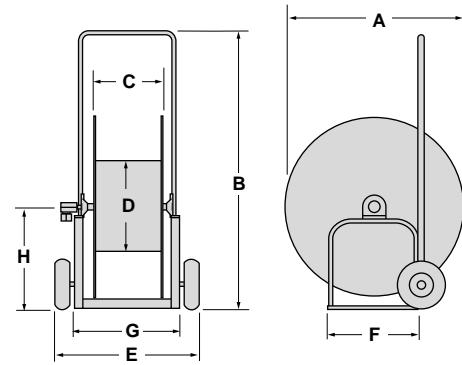

Gleason Reel

P.O. Box 26 • 600 South Clark Street

Mayville, WI 53050

Phone 920-387-4120 • Fax 920-387-4189

REPRESENTED BY:

