

GLEASON **PowerTrak[®] GRP**

**Type "G" Molded Nylon Side Link
Cable/Hose Carrier**

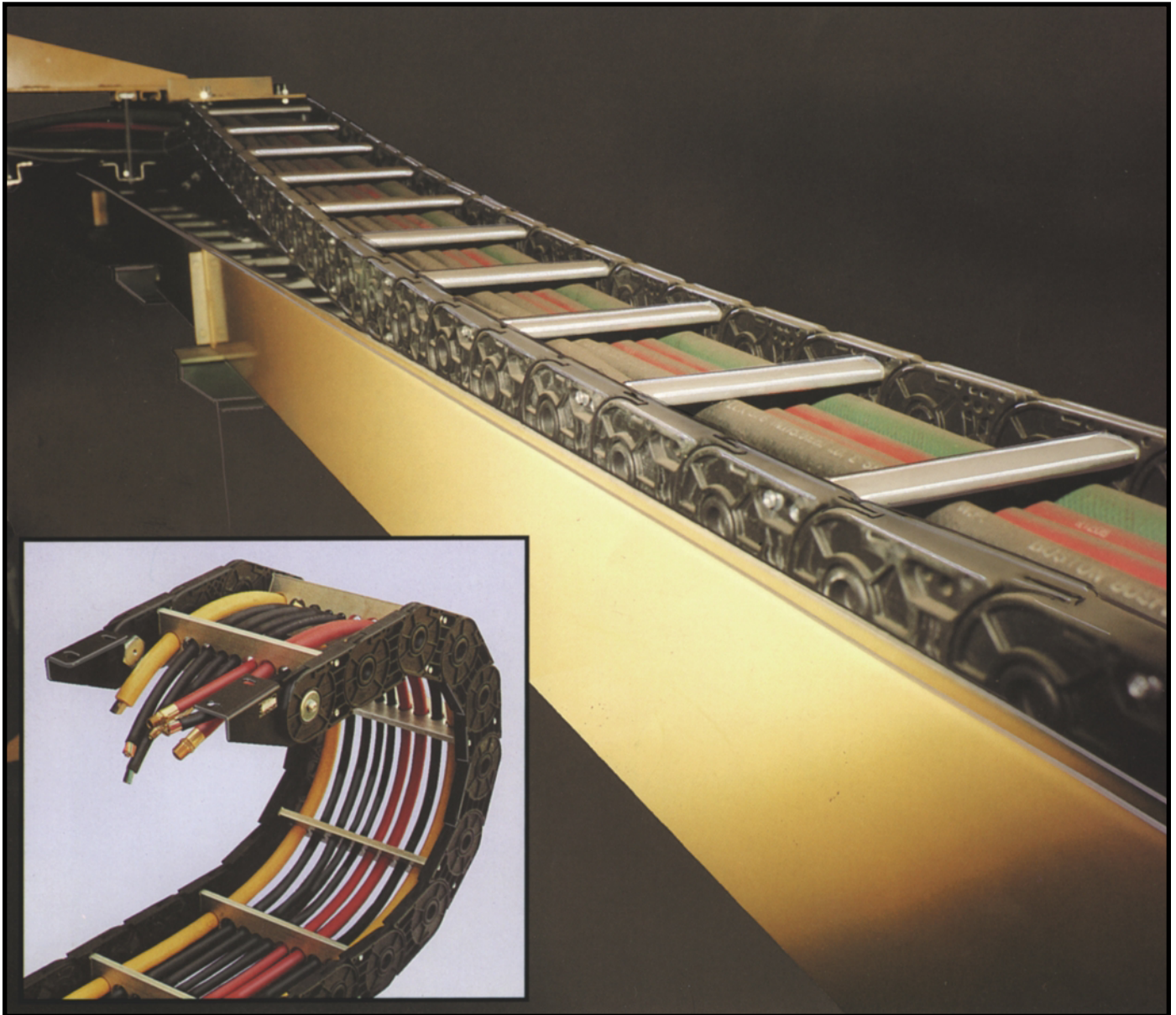

with Patented Carriage System



Spec Tech Industrial 203 Vest Ave. Valley Park, MO 63088 Phone: 888 SPECTECH
E-mail: sales@spectechind.com www.spectechind.com

GPT-4

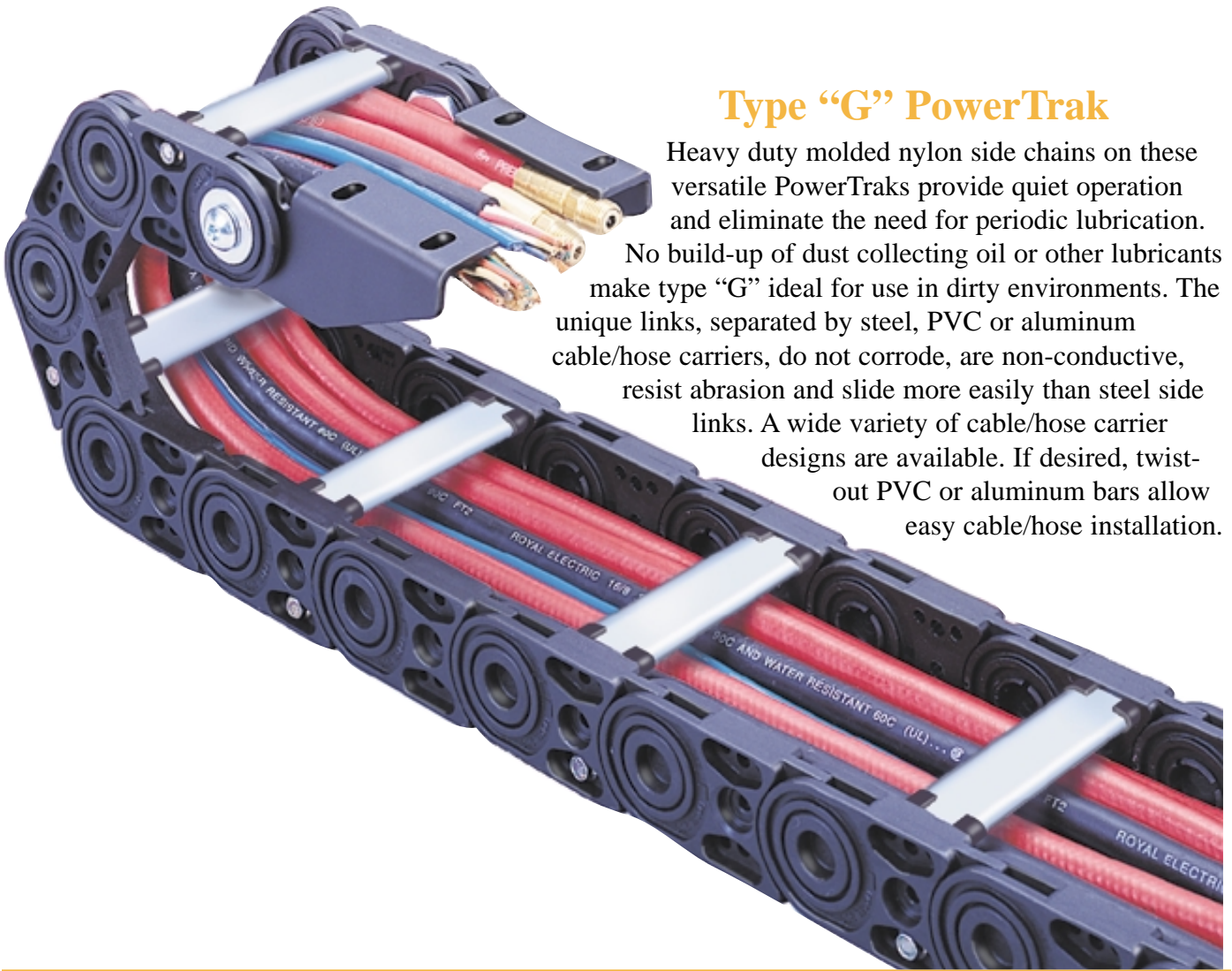

Type “G” PowerTrak

Heavy duty molded nylon side chains on these versatile PowerTraks provide quiet operation and eliminate the need for periodic lubrication.

No build-up of dust collecting oil or other lubricants make type “G” ideal for use in dirty environments. The unique links, separated by steel, PVC or aluminum cable/hose carriers, do not corrode, are non-conductive, resist abrasion and slide more easily than steel side links. A wide variety of cable/hose carrier designs are available. If desired, twist-out PVC or aluminum bars allow easy cable/hose installation.

PowerTrak is available in a variety of styles and materials. Metallic or non-metallic, Gleason offers a carrier trak to fit every application.

- **Five types**
- **Many carrier styles**
- **Hundreds of sizes**
- **Custom lengths**

Protect cables and hoses on reciprocating machinery. Increase safety by keeping cables and hoses together, away from moving components and operations.

PowerTrak is available in a variety of styles and materials, including flip-open for easy access to cables and hoses. Metallic or non-metallic, Gleason offers a carrier trak to fit every application.

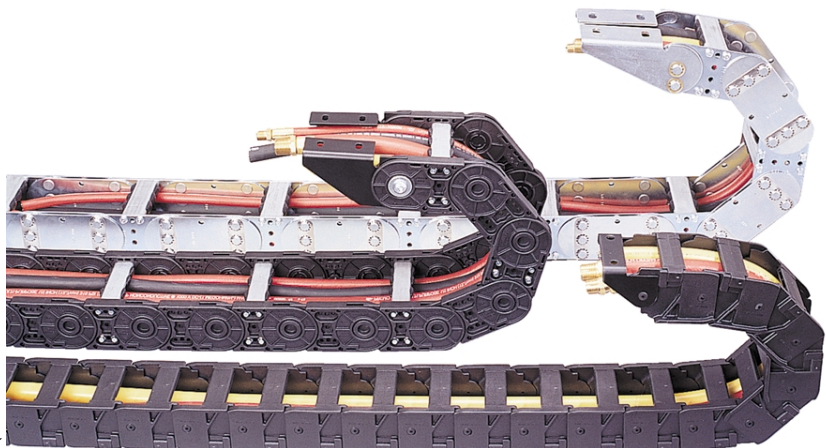

Available In This Catalog...

GLEASON **PowerTrak[®] GRP**

Models 25G, 28G, 35G, 45G

Type "G" PowerTrak is available with inside openings from 0.75" x 4.00" to 3.09" x 18.00" with maximum total travel to 800 feet. Molded fiber-glass reinforced nylon side chains do not corrode, are non-conductive, resist abrasion and slide easier than steel side chains of same size. Wide choice of carriers allow customizing to best suit application needs. Superior material strength, with or without optional guide trays or carriers, allows service at greater length and higher speeds than is possible with normal plastic trak.

Contents

General Information	
PAGE	
Application Photos4
Product Description and Definitions5
Applying PowerTrak	6-8
Carrier Options9
Guide Trays	18-19
Carriage Systems20
Optional Accessories26
Selection and Ordering	
PAGE	
Selecting and Ordering PowerTrak21-25
Technical Data	
PAGE	
PowerTrak Series G Data by Type	
Type 25G	10-11
Type 28G	12-13
Type 35G	14-15
Type 45G	16-17
Chain Material Data27
Cable & Hose Data28

WARRANTY

© Copyright 2001 Gleason Reel Corp.

Gleason warrants for a period of twelve (12) months after date of shipment, all goods manufactured by it to be free from defects in material and workmanship. If, within such warranty period, any such goods are proved, to Gleason's satisfaction, to be defective, such goods shall be repaired or, at Gleason's option, replaced f.o.b. Gleason's factory, without charge. Gleason's obligation hereunder shall be confined to such repair or replacement and shall be further conditioned upon Gleason receiving written notice of any alleged defect within 10 days after its discovery and, at Gleason's option, the return of the alleged defective goods to Gleason, f.o.b. its factory.

The foregoing warranty shall not apply to goods not manufactured by Gleason, or to goods which shall have been repaired or altered by others than Gleason so as to, in Gleason's judgement, adversely affect the same, or which shall have been subject to other than normal use of service, negligence, accident, or improper maintenance care, or storage. With respect to goods furnished but not manufactured by Gleason, the warranty obligations of Gleason shall in all respects conform and be limited to the warranty extended to Gleason by the supplier.

The foregoing warranty is in lieu of all other express or implied warranties (except of title) and of all other obligations of Gleason.

GLEASON **PowerTrak** GRP

Long Lasting • Ideal for High Cycle Applications

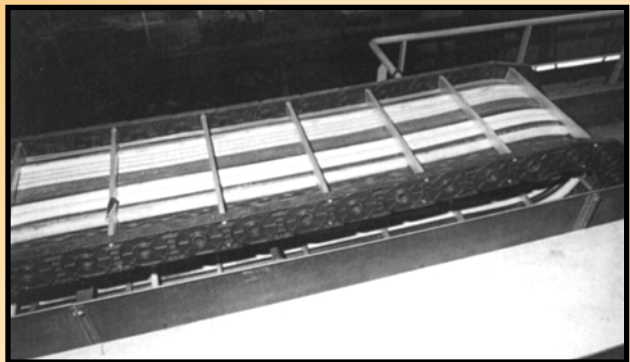
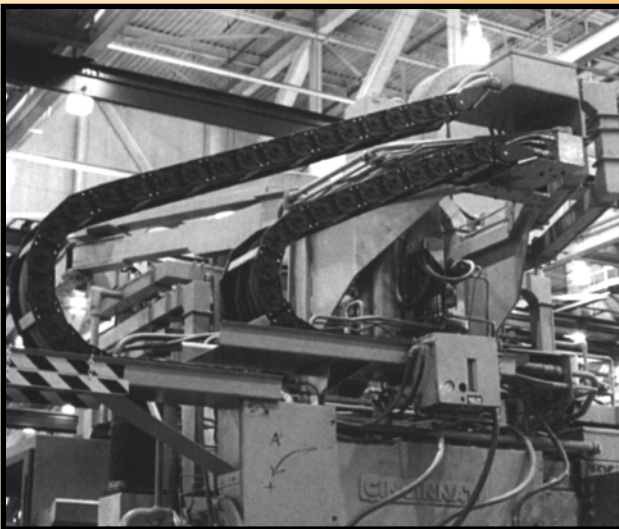
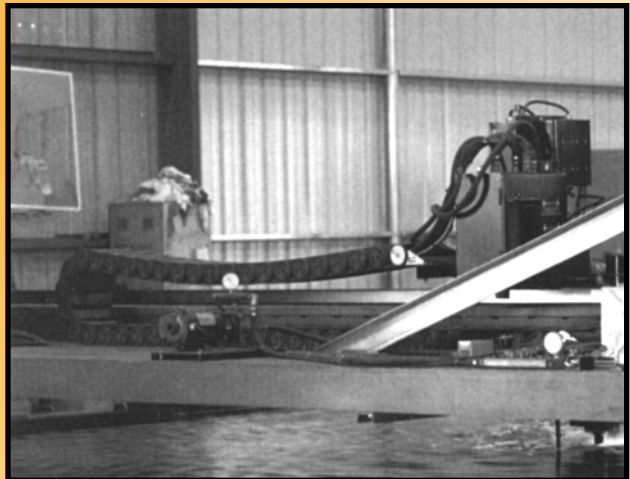
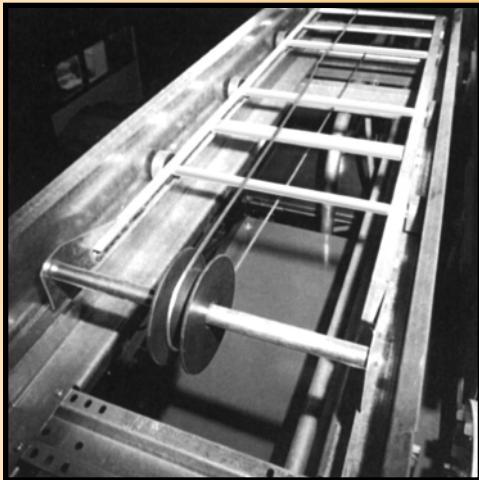
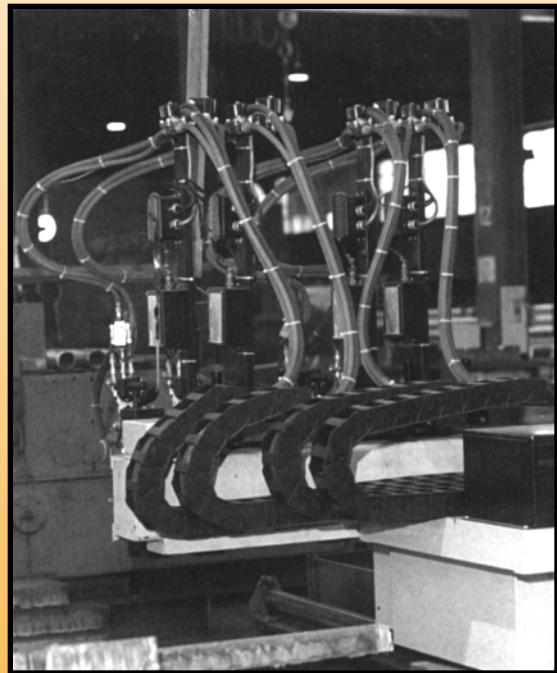
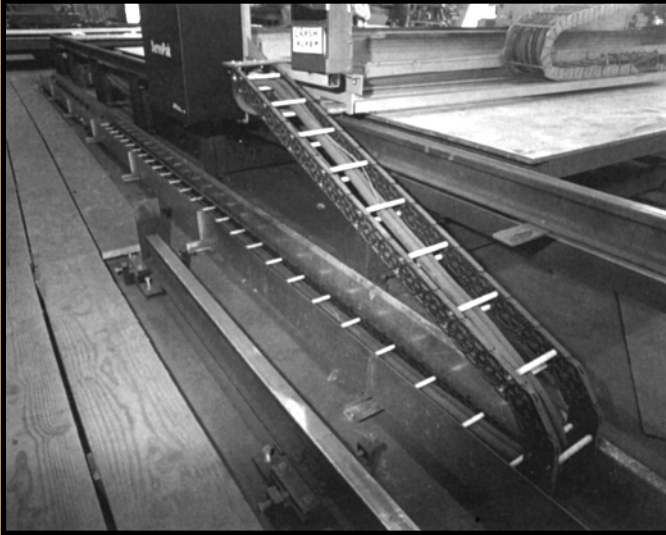

What is type “G” PowerTrak?

Type “G” PowerTrak controls and protects electric cables and hydraulic or other hoses providing power to machines having repetitive motion... robots, machine tools, cranes, etc. Cables and hoses may be bundled together in a single trak or separated by using a double or triple width trak, by installing two traks opposing each other as illustrated at the bottom of the page, or by nesting two traks in a single tray. PowerTrak may also be used for vertical travel.

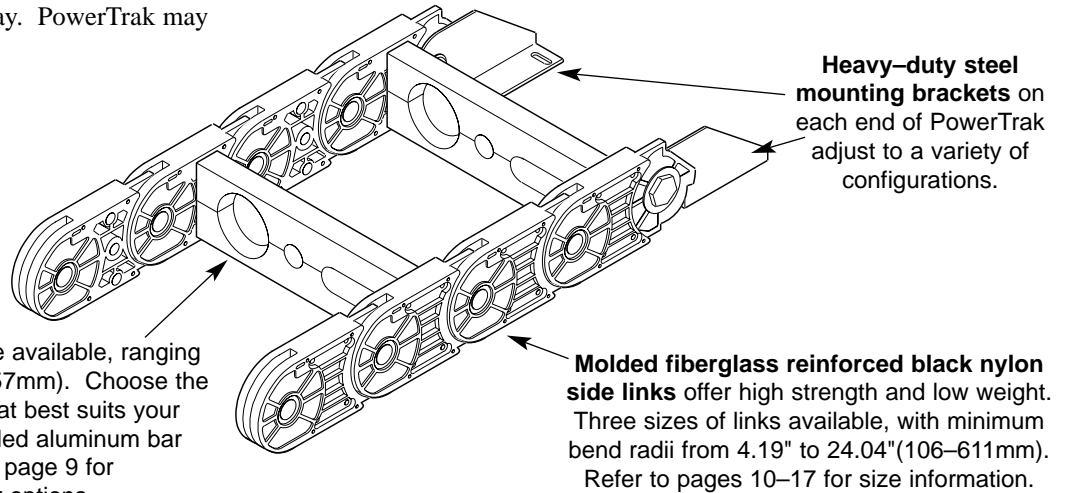

DEFINITIONS

Carriage– A patented Gleason exclusive. An optional wheeled frame installed between the lower and upper portions of the trak. It reduces friction and wear, allowing greater travel lengths and higher speeds. Refer to page 20 for more information.

Carrier– Bars or rods which connect the right and left links and carry the cable or hose. Normally there is one carrier per two links (every other link) the entire length of the trak. See pages 10 – 17 for complete information.

Fixed end– End of PowerTrak affixed to stationary support, usually on bottom. See diagram below.

Fixed roller support– Rollers which support free hanging section of trak to minimize sag. See “Free hanging section”, “Sag”.

Free hanging section– Portion of trak which is “on top” in horizontal installation, with its end attached to the tow arm on the machine. Also called “upper section”. See diagram below.

Guide tray– Metal trough which supports and guides PowerTrak. Recommended for use with long trak. Must be used when carriage is used. See pages 18 – 19.

Half travel– Total travel divided by two, or one-half distance machine travels. Equals length of travel required by two-way payout trak. See *APPLYING POWERTRAK*, pages 6 – 8.

Movable end– End of PowerTrak affixed to tow bar on machine. See diagram below.

Nested travel– Two PowerTraks having different bend radii allowing one to nest within the other. Increases operating life, allows reduction of overall width and provides way to segregate hoses and cables.

One-way payout– Trak mounted with fixed end at one end of Total Travel. Machine moves away from mounting point, then back. See page 7.

Opposed travel (below)– Two PowerTraks mounted with common fixed and movable end points so they operate simultaneously but in opposite directions to service one machine. Generally used when single trak will not carry required cables/ hoses or to isolate cables from hoses or from other cables.

Sag– “Droop” of free hanging section in unsupported span.

Standard travel– Single PowerTrak serving one machine. May be either one-way or two-way payout.

Total Travel(TT)– Maximum distance machine can travel.

Two-way payout– Trak mounted with fixed end in center of machine travel. Provides full travel with half the trak.

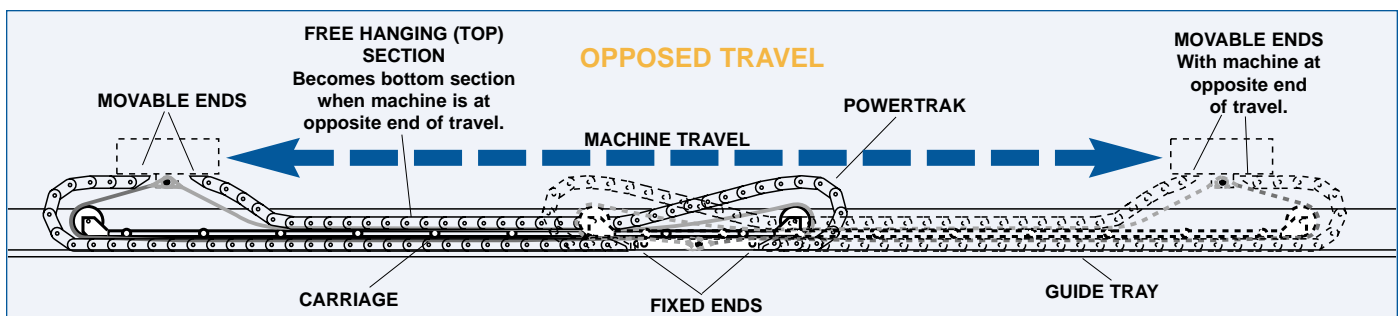

Applying type "G" PowerTrak

PowerTrak is most often used in the horizontal Standard Travel configurations, described on this page. TWO-WAY PAYOUT is normally used with Standard Travel.

Two-way payout means locating the cable/hose source at the CENTER of machine travel so that cables/hoses are used in TWO directions. Thus, using two-way payout, the PowerTrak you order will be just one-half of the Total Travel distance that you require, plus a little more to form the curve, as illustrated below.



STANDARD TRAVEL

- Two-way payout (center-fed)
- Upper section is self-supported, roller supported or, for extended travel, may ride on itself or on a carriage
- Lower section is supported by a surface

Adding Roller Supports

Roller supports present a useful option when applying PowerTrak. While larger sizes of PowerTrak have greater Total Travel capabilities, smaller sizes can have their capabilities increased by adding roller supports.

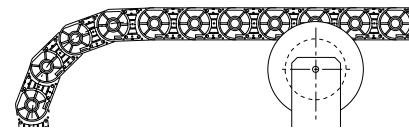

Stationary roller supports increase the travel or weight capacity capabilities of PowerTrak by supporting the upper, or "free hanging" section.

STANDARD TRAVEL Plus ONE Roller

- Two-way payout (center-fed)
- Upper section is supported by ONE roller support
- Lower section is supported by a surface
- **Total Travel capability increases by 50%**

STANDARD TRAVEL Plus TWO Rollers

- Two-way payout (center-fed)
- Upper section is supported by TWO roller supports
- Lower section is supported by a surface
- **Total Travel capability increases by 100% (doubles)**

Variations

Opposed Travel is the most common variation to Standard Travel. Two smaller PowerTraks in the Opposed configuration can do the same work as a larger size using Standard Travel. Opposed Travel is a valid option when there are width restrictions or when cables and hoses must be separated.



Opposed Travel involves TWO PowerTraks opposed to one another, each operating in the Standard Travel configuration. Cables/hoses are distributed between the two PowerTraks increasing operating life. Length of each trak is same as one standard travel trak in given application, but type and width of trak may be smaller.

OPPOSED TRAVEL

- TWO PowerTraks, two-way payout on each
- Upper sections self-supported or may ride on lower section or carriage
- Lower sections are supported by a surface
- Roller supports are not available
- Overall width may be reduced
- Cables and hoses may be separated

Other Variations

One Way Travel

Applied where situation prohibits center-feeding of cables/hoses. Roller supports may be added to increase Total Travel capabilities.

- ONE-WAY payout (end-fed in relation to machine travel)
- Upper section is SELF-SUPPORTING
- Lower section is supported by a surface
- Roller supports may be added — consult factory

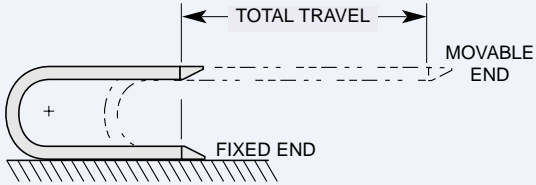

Nested Travel

Two PowerTraks having different bend radii allowing one to nest within the other. Cables/hoses are distributed between the two PowerTraks increasing operating life.

- TWO PowerTraks, two-way payout on each
- Upper sections must be SELF-SUPPORTING
- Lower sections are supported by a guide tray
- Both PowerTraks must be same width
- Roller supports are not available
- ⇒ Overall width may be reduced
- ⇒ Cables and hoses may be separated

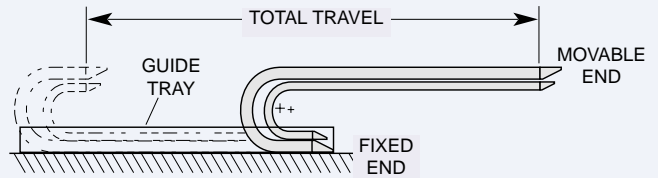

Vertical Travel

CURVE AT TOP

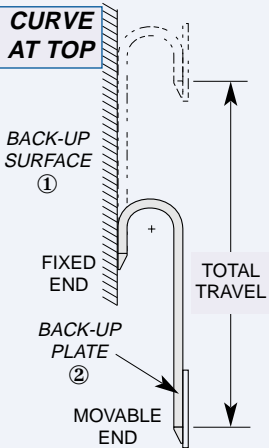

Vertical Travel in the Curve at Top or Curve at Bottom configuration is possible when PowerTrak is properly supported:

- A back-up SURFACE ① is preferred for one side of the PowerTrak.
- A back-up PLATE ② must extend a minimum of four (4) links.

- Typically two-way payout (center-fed)
- Back-up surface ① and back-up plate ② used to support PowerTrak
- ⇒ Curve at Bottom provides greater Total Travel capabilities than Curve at Top.

CURVE AT BOTTOM

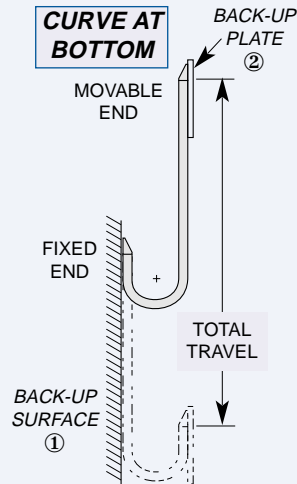

Lift

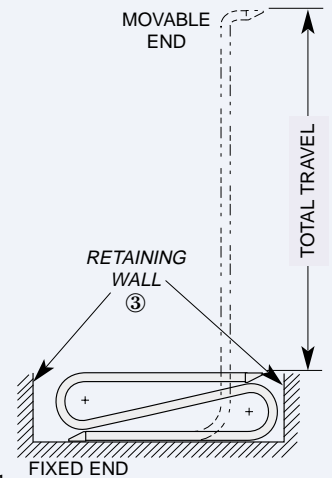

Lifting is possible when PowerTrak is properly supported:

- Vertical retaining walls extending the full height of PowerTrak in the stored position are required.

- ONE-WAY payout
- END-FED (“Bottom Fed”) in relation to machine travel
- Upper section is SELF-SUPPORTING
- Lower section is fully supported
- Vertical retaining walls ③ required
- Special reverse bend links are required

Combination Travel

PowerTrak can travel the full vertical and horizontal range of motion illustrated.

- Vertical & horizontal payout
- Typically CENTER-FED
- Upper section is SELF-SUPPORTING
- Lower section is fully supported

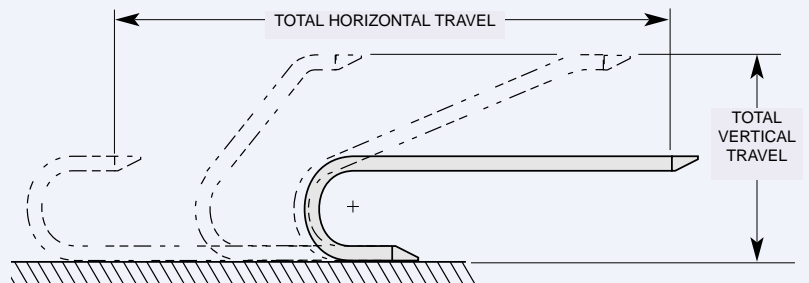

Other Variations

Linked Side-by-side Travel

PowerTrak side chains may be modified to allow for Double-Wide or Triple-Wide configurations. Contiguous Travel is a useful option when PowerTrak exceeds its Total Travel capabilities in the Standard Travel configuration.

- TWO or THREE PowerTraks, two-way payout on each
- Upper sections are self-supporting
- Lower sections are supported by a surface
- Not for use with all carriers. Consult factory.
- ⇨ Overall height may be reduced
- ⇨ Cables and hoses may be separated

DOUBLE-WIDE

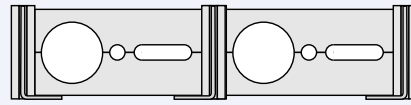

TRIPLE-WIDE

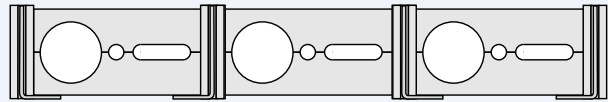

Traveling on Edge

PowerTrak will travel on its edge with the addition of a guide tray ①. Edge-travel distributes cable/hose weight over a greater support area for improved life expectancy and is typically chosen when height restrictions apply.

- Two-way payout (center-fed)
- PowerTrak is fully supported by guide tray
- ⇨ Overall height may be reduced
- ⇨ Improved life expectancy for PowerTrak

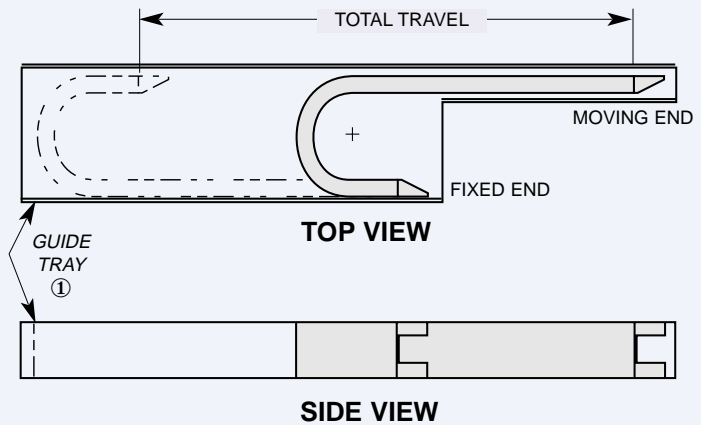

Circular Travel

Circular Travel is possible when PowerTrak is modified to bend in two directions. PowerTrak travels on its edge on a two-piece, circular guide tray. The inner tray (light shading) rotates while the outer tray (dark shading) remains fixed. TYPICAL APPLICATIONS INCLUDE stacker cranes and stacker-reclaimer machines.

- Typically two-way payout (center-fed)
- PowerTrak is fully supported by guide tray
- Two-piece Guide Tray for free rotation
- PowerTrak is modified to bend in two directions

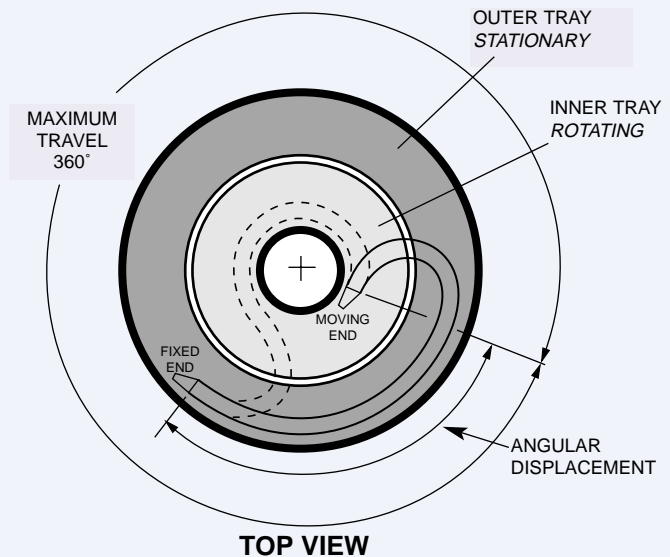

CARRIER OPTIONS

TYPE BC MACHINED BAR CARRIER

Most efficient carrier design available. Machined bar provides maximum protection for cables and hoses in PowerTrak® by placing each, regardless of size, on a common centerline. Removable two-piece bar allows easy access. Standard material is aluminum. Surface hardened aluminum and nylon with steel reinforcing rods are also available. Consult factory for details.

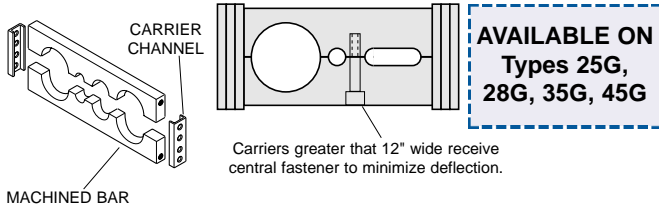

TYPE RR REMOVABLE ROD CARRIER

Sold as a set, the removable rod, or "quick access" carrier, features a removable ROLLING rod on top and an aluminum channel on the bottom. The rod is spring-loaded for quick removal using a standard screwdriver and is securely fixed when in use. The rolling rod reduces wear on cables/hoses. Type RR carriers are limited to a width of 10".

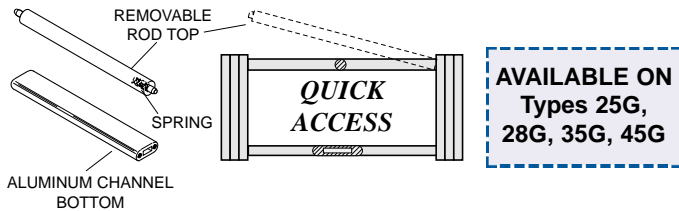

TYPES AC, A1, VC & V1 ALUMINUM or PVC CHANNEL CARRIER

Channel carriers feature a wide support area and light weight. Four-point fastening on each channel creates an extremely rigid and stable PowerTrak®, rivaling welded carriers. Types A1 & V1 (A2, A3, etc.) includes molded nylon separator(s) which may be positioned to prevent cable/hose entanglement and allow grouping of various types of conductors.

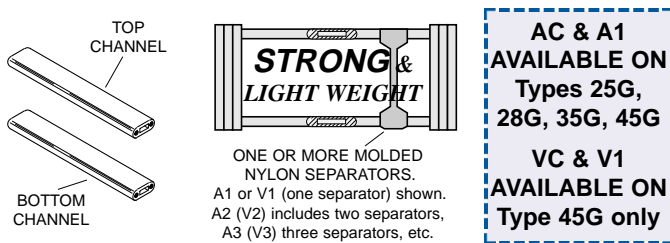

TYPES TB, T1, VTB, VT1 SNAP OUT ALUMINUM or PVC CHANNEL CARRIER

One channel snaps out for quick access to cables/hoses. Type T1 & VT1 (T2, T3, etc.) include tough, break resistant nylon separator(s) which may be easily positioned where needed on the channels.

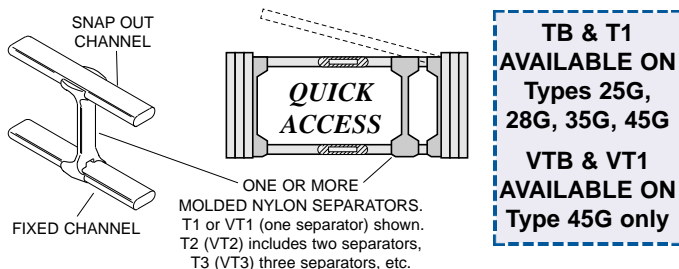

TYPES SR & XR STEEL ROD CARRIER

Provides basic support for cables and hoses. Steel rods are economical, light weight and are easily removed for cable/hose access. Type XR provides over 1/2" additional clearance between rods.

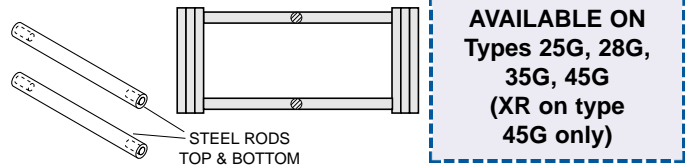

TYPE R1 & X1 REMOVABLE ROD CARRIER with NYLON SEPARATORS

Tough molded nylon separators provide partitions to prevent cable/hose entanglement and allow conductor grouping. One or more separators may be used as needed. Spacing of separators adjustable along complete length of rods.

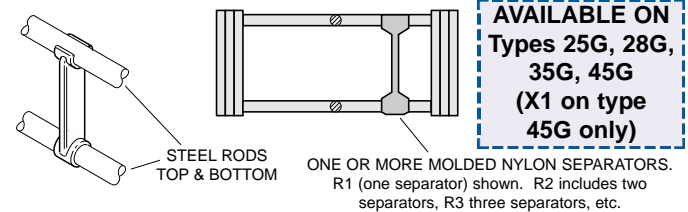

TYPES RN & XN STEEL ROD CARRIER with NYLON SLEEVES

Nylon sleeves roll when in contact with jacketed cable and hoses, increasing useful life. Type XN, with over 1/2" of additional clearance between rods, provides for greater capacity than type RN carrier.

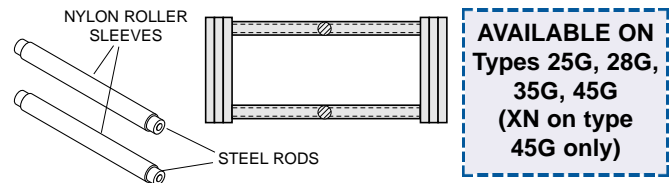

TYPES RB, RB1, TRB & TR1 (patented) ALUMINUM CHANNEL CARRIER with NYLON ROLLERS. TWIST OUT or FULLY BOLTED.

The ultimate carrier. Cable and hose moves smoothly on top and bottom nylon rollers. Optional Twist out design eases cable and hose installation. Tough nylon retainers at both ends of strong aluminum channel and roller assemblies provide superior rigidity and stability.

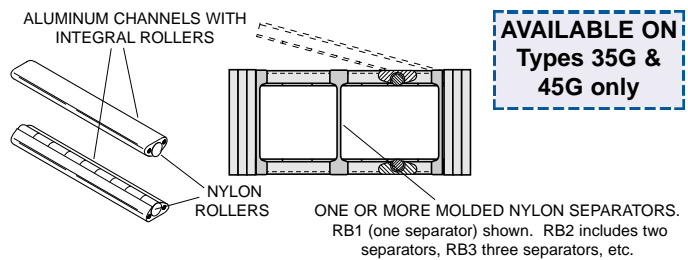

CUSTOM DESIGNED CARRIERS WITH HORIZONTAL SEPARATORS

Horizontally divided carriers are desirable when very large and very small cables are mixed within the carrier or when there are numerous small cables/hoses. Consult factory for more information.

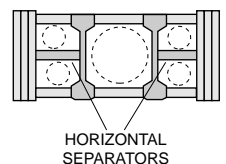

25G

GLEASON PowerTrak[®] GRP

- HEAVY DUTY DESIGN AND CONSTRUCTION
- SIDE CHAIN IS GLASS FIBER REINFORCED NYLON
- VARIETY OF CARRIER STYLES & SIZES
- RADII "A" AVAILABLE 2.78", 4.95", 7.70" & 11.64"
- TOTAL TRAVEL = 14.0 FT. (1)
- GUIDE TRAYS OR CARRIAGES NOT AVAILABLE

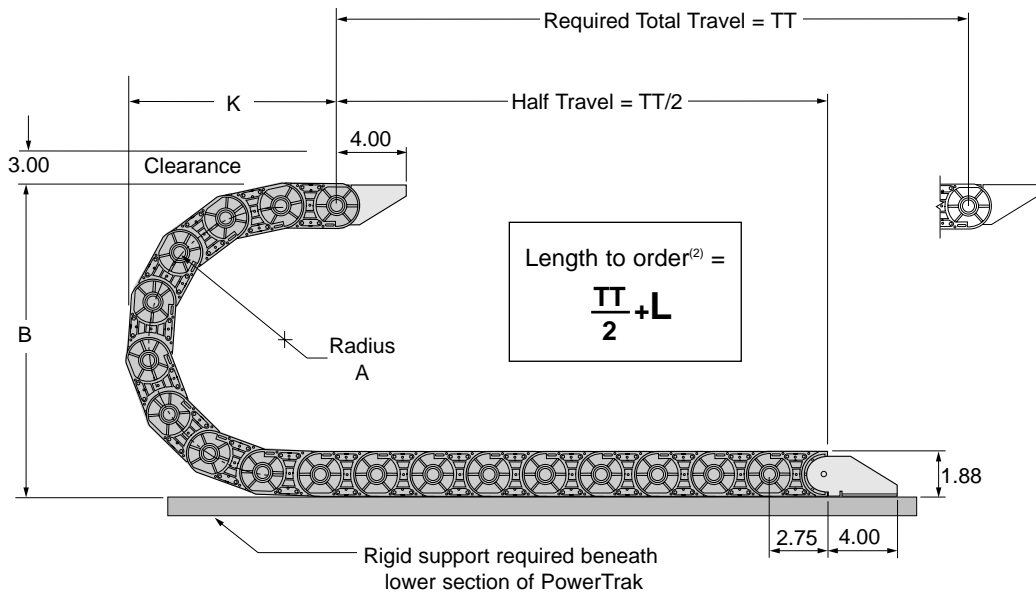

25G Dimensions

Inches unless otherwise indicated

RADIUS A	HEIGHT B	MINIMUM K	CURVE L ⁽³⁾
2.78	7.64	8.35	1.5 ft.
4.95	11.77	10.11	2.0 ft.
7.70	17.28	11.54	2.5 ft.
11.64	25.16	15.29	3.5 ft.

NOTES:

- (1) Total Travel is nominal, based on standard travel with cable/hose package weight of 0.5 lb/ft., and may vary with environment.
- (2) For standard travel, i.e. two-way payout as pictured above.
- (3) L = Minimum length in FEET to form PowerTrak curve.
- (4) Indicates width in inches.

WEIGHT FORMULA, side chains and carriers only: $0.83 + (C \times 0.12) = \text{weight (lbs/ft.)}$. C = carrier width in inches.
 For total weight: Trak weight (lbs/ft.) + cable/hose weight (lbs/ft.) x Trak length (ft.)

Model Number Explanation

POWERTRAK TYPE	CARRIER TYPE	RADIUS	CARRIER WIDTH ⁽⁴⁾
PT 25G	BC*	5.4	10
	BC*, T1, AC, SR, R1, RN, A1, TB, RR**	2.78", 4.95", 7.70", 11.64"	4, 6, 8, 10, 12

*Please provide machining pattern with order for type BC carriers. **Maximum carrier width for type RR is 10".

25G Carrier Types & Dimensions

ALL DIMENSIONS IN INCHES

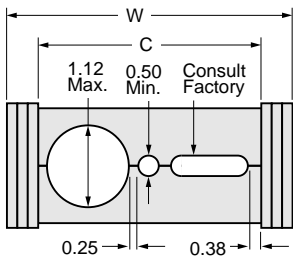

TYPE BC

Aluminum bars standard. Nylon also available. Consult factory.

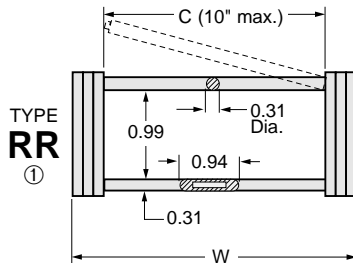

TYPE RR

①

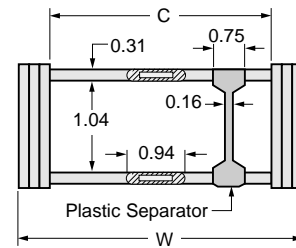

WITHOUT SEPARATOR TYPE AC

WITH SEPARATOR(S) TYPE A1^②

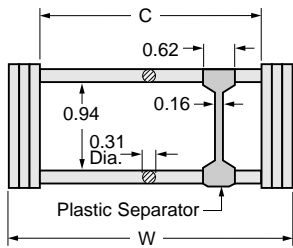

WITHOUT SEPARATOR TYPE SR

WITH SEPARATOR(S) TYPE R1^②

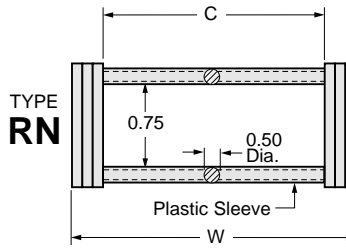

TYPE RN

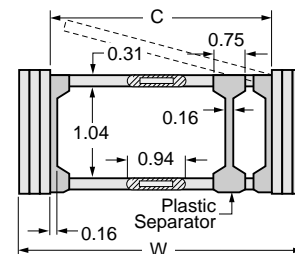

WITHOUT SEPARATOR TYPE TB

WITH SEPARATOR(S) TYPE T1^②

Dimensions in Inches

CARRIER WIDTH* C	POWERTRAK WIDTH W
4.00	5.25
6.00	7.25
8.00	9.25
10.00	11.25
12.00	13.25
Formula	C + 1.25

*Special widths available. Consult factory.

NOTES:

- ① Carrier type RR limited to "C" dimension no greater than 10.00".
- ② Numeral "1" refers to the number of vertical separators desired and must be included in the model number when ordering. For example: R1 (as above), R2 (2 separators), R3 (3 separators), etc.

NOTE:

Separators are recommended for multiple cable/hose packages to create smaller groups resulting in longer cable/hose life. Separators are adjustable and can be positioned anywhere along the carrier's width.

Mounting Brackets

Dimensions in Inches

CARRIER WIDTH C	FEET TURNED IN		FEET TURNED OUT		
	MTG. LOCATION E ± .06	OVER BRKTS F1 F2	MTG. LOCATION G ± .06	OVER BRKTS H1 H2	
4.00	3.18	4.68 5.06	6.07	7.07	7.09
6.00	5.18	6.68 7.06	8.07	9.07	9.09
8.00	7.18	8.68 9.06	10.07	11.07	11.09
10.00	9.18	10.68 11.06	12.07	13.07	13.09
12.00	11.18	12.68 13.06	14.07	15.07	15.09
Formula	C - 0.82	C + 0.68 C + 1.06	C + 2.07	C + 3.07	C + 3.09

When ordering PowerTrak mounting brackets, specify end and flange arrangement (ie: Brackets both ends, flanges inward).

Foot Mounting Options

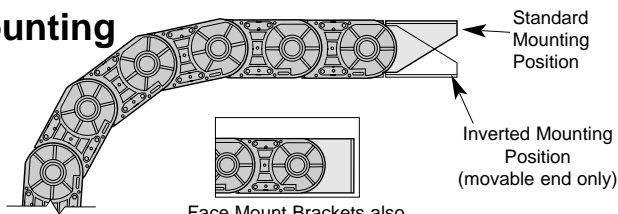

Face Mount Brackets also Available. Consult factory.

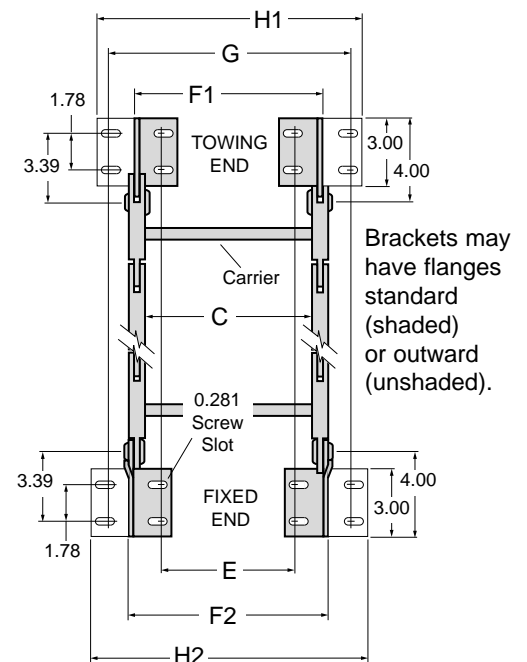

Brackets may have flanges standard (shaded) or outward (unshaded).

28G

GLEASON PowerTrak[®] GRP

- HEAVY DUTY DESIGN AND CONSTRUCTION
- SIDE CHAIN IS GLASS FIBER REINFORCED NYLON
- VARIETY OF CARRIER STYLES & SIZES
- RADII "A" AVAILABLE 4.19", 5.45", 6.63" & 8.40"
- TOTAL TRAVEL = 18.0 FT. (1)
- TOTAL TRAVEL W/GUIDE TRAY = 300 FT. (2)
- TOTAL TRAVEL W/GUIDE TRAY & CARRIAGE = 400.0 FT. (2)

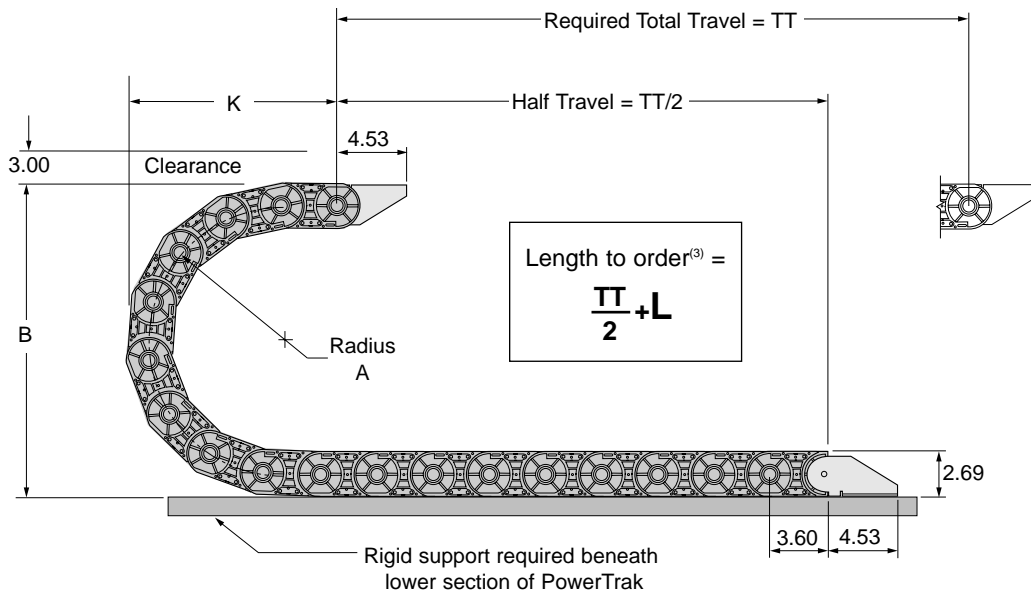

28G Dimensions

Inches unless otherwise indicated

RADIUS A	HEIGHT B	MINIMUM K	CURVE L ⁽⁴⁾
4.19	11.06	7.95	1.5 ft.
5.45	13.58	10.24	2.0 ft.
6.63	15.94	12.56	2.5 ft.
8.40	19.49	14.55	3.0 ft.

NOTES:

- (1) Total Travel is nominal, based on standard travel with cable/hose package weight of 0.5 lb/ft., and may vary with environment. GREATER TRAVELS CAN BE ACHIEVED if PowerTrak is allowed to glide within a guide tray.
- (2) GREATER TRAVELS IN TRAYS CAN BE ACHIEVED. Consult the factory.
- (3) For standard travel, i.e. two-way payout as pictured above.
- (4) L= Minimum length in FEET to form PowerTrak curve.
- (5) Indicates width in inches.

WEIGHT FORMULA, side chains and carriers only: $1.32 + (C \times 0.12) = \text{weight (lbs/ft.)}$. C = carrier width in inches.

For total weight: Trak weight (lbs/ft.) + cable/hose weight (lbs/ft.) x Trak length (ft.)

Model Number Explanation

POWERTRAK TYPE	CARRIER TYPE	RADIUS	CARRIER WIDTH ⁽⁵⁾
PT 28G	BC*	5.4	10
	BC*, T1, AC, SR, R1, RN, A1, TB, RR**	4.19", 5.45", 6.63", 8.40"	4, 6, 8, 10, 12

*Please provide machining pattern with order for type BC carriers. **Maximum carrier width for type RR is 10".

28G Carrier Types & Dimensions

ALL DIMENSIONS IN INCHES

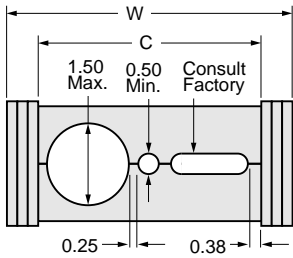

TYPE BC
Aluminum bars standard. Nylon also available. Consult factory.

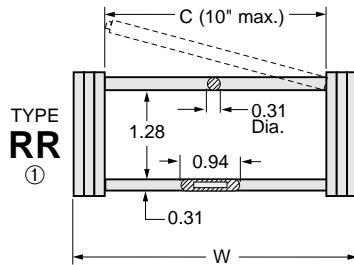

TYPE RR
①

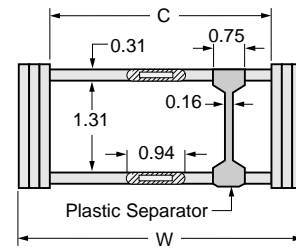

WITHOUT SEPARATOR
TYPE
AC
WITH SEPARATOR(S)
TYPE
A1②

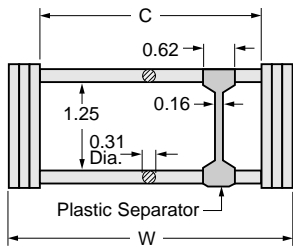

WITHOUT SEPARATOR
TYPE
SR
WITH SEPARATOR(S)
TYPE
R1②

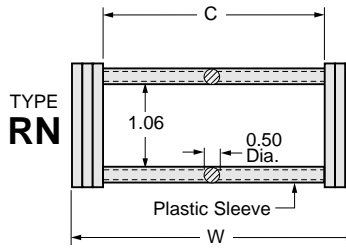

TYPE RN

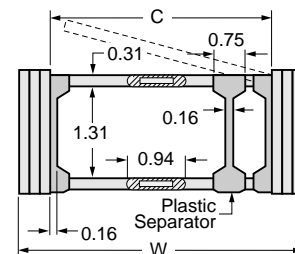

WITHOUT SEPARATOR
TYPE
TB
WITH SEPARATOR(S)
TYPE
T1②

Dimensions in Inches

CARRIER WIDTH* C	POWERTRAK WIDTH W
4.00	5.34
6.00	7.34
8.00	9.34
10.00	11.34
12.00	13.34
Formula	C + 1.34

*Special widths available. Consult factory.

NOTES:

- Carrier type RR limited to "C" dimension no greater than 10.00".
- Numeral "1" refers to the number of vertical separators desired and must be included in the model number when ordering. For example: R1 (as above), R2 (2 separators), R3 (3 separators), etc.

NOTE:

Separators are recommended for multiple cable/hose packages to create smaller groups resulting in longer cable/hose life. Separators are adjustable and can be positioned anywhere along the carrier's width.

Mounting Brackets

Dimensions in Inches

CARRIER WIDTH C	FEET TURNED IN		FEET TURNED OUT		
	MTG. LOCATION E ± .06	OVER BRKTS F1 F2	MTG. LOCATION G ± .06	OVER BRKTS H1 H2	
4.00	3.18	4.74 5.13	6.16	7.54 7.14	
6.00	5.18	6.74 7.13	8.16	9.54 9.14	
8.00	7.18	8.74 9.13	10.16	11.54 11.14	
10.00	9.18	10.74 11.13	12.16	13.54 13.14	
12.00	11.18	12.74 13.13	14.16	15.54 15.14	
Formula	C - 0.82	C + 0.74 C + 1.13	C + 2.16	C + 3.54 C + 3.14	

When ordering PowerTrak mounting brackets, specify end and flange arrangement (ie: Brackets both ends, flanges inward).

Foot Mounting Options

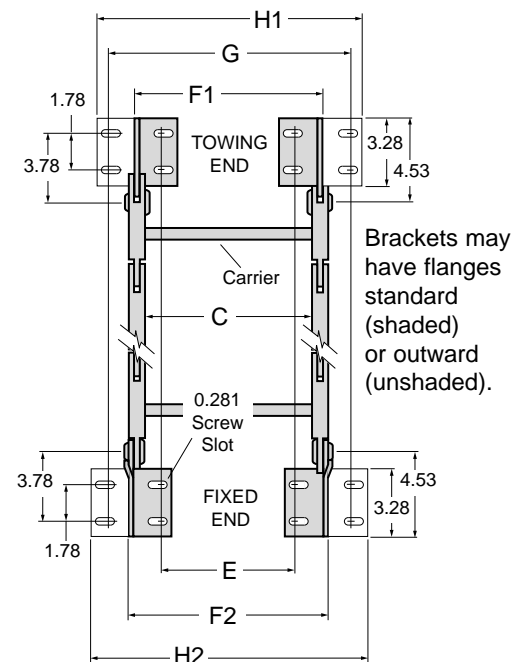
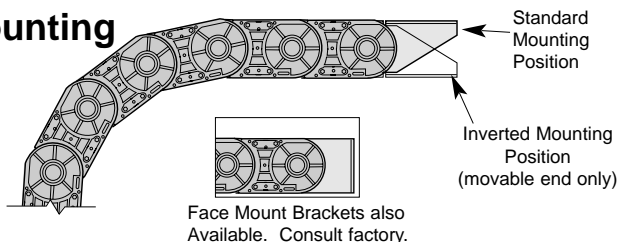

35G

GLEASON PowerTrak[®] GRP

- HEAVY DUTY DESIGN AND CONSTRUCTION
- SIDE CHAIN IS GLASS FIBER REINFORCED NYLON
- VARIETY OF CARRIER STYLES & SIZES
- RADII "A" AVAILABLE 4.94", 7.21", 10.84" & 14.71"

- TOTAL TRAVEL = 24.0 FT. (1)
- TOTAL TRAVEL W/GUIDE TRAY = 300 FT. (2)
- TOTAL TRAVEL W/ GUIDE TRAY & CARRIAGE = 700 FT. (2)

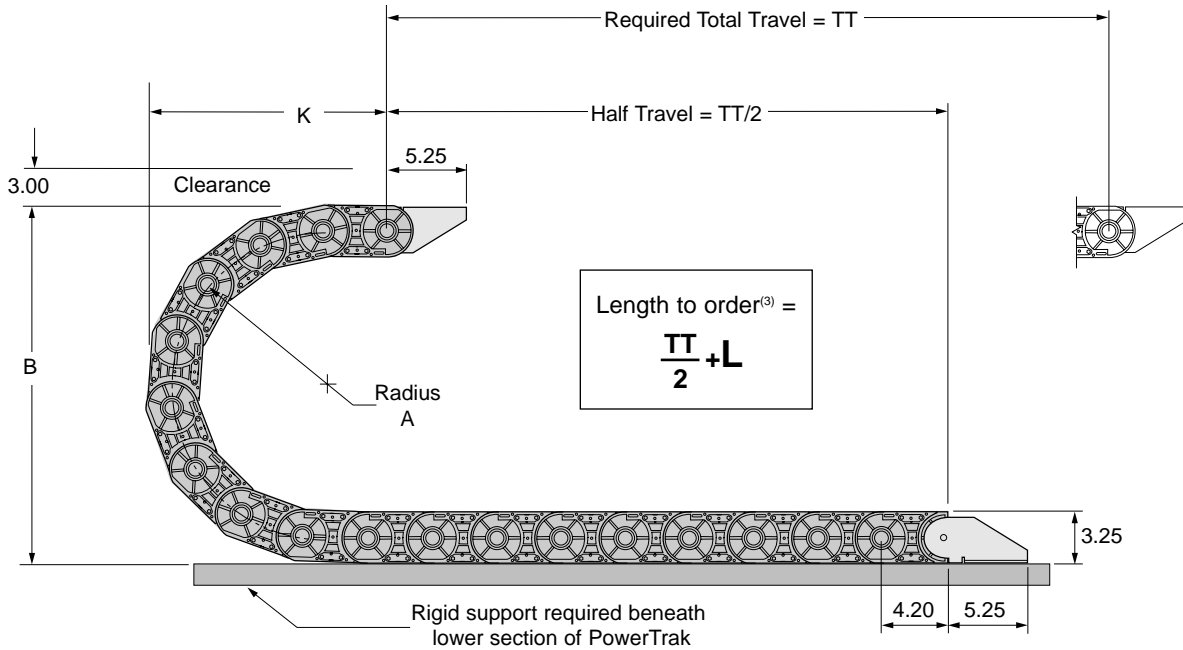

35G Dimensions

Inches unless otherwise indicated

RADIUS A	HEIGHT B	MINIMUM K	CURVE L ⁽⁴⁾
4.94	13.12	10.80	2.0 ft.
7.21	17.68	15.50	3.0 ft.
10.84	24.93	19.40	4.5 ft.
14.71	32.68	23.20	5.0 ft.

NOTES:

- (1) Total Travel is nominal, based on standard travel with cable/hose package weight of 0.5 lb/ft., and may vary with environment. GREATER TRAVELS CAN BE ACHIEVED if PowerTrak is allowed to glide within a guide tray.
- (2) GREATER TRAVELS IN TRAYS CAN BE ACHIEVED. Consult the factory.
- (3) For standard travel, i.e. two-way payout as pictured above.
- (4) L = Minimum length in FEET to form PowerTrak curve.
- (5) Indicates width in inches.

WEIGHT FORMULA, side chains and carriers only: $1.79 + (C \times 0.13) = \text{weight (lbs/ft.)}$. C = carrier width in inches.
 For total weight: $\text{Trak weight (lbs/ft.)} + \text{cable/hose weight (lbs/ft.)} \times \text{Trak length (ft.)}$

Model Number Explanation

POWERTRAK TYPE	CARRIER TYPE	RADIUS	CARRIER WIDTH ⁽⁵⁾
PT 35G	BC*	7.2	10
	BC*, AC, SR, R1, RN, A1, TB, T1, RB, RB1, RR**	4.94", 7.21", 10.84", 14.71"	4, 6, 8, 10, 12, 14, 16, 18

*Please provide machining pattern with order for type BC carriers. **Maximum carrier width for type RR is 10".

35G Carrier Types & Dimensions

ALL DIMENSIONS IN INCHES

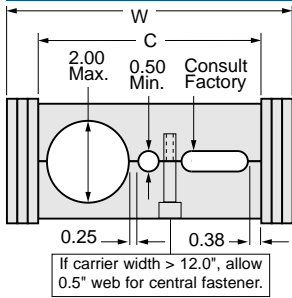

TYPE BC

Aluminum bars standard. Nylon also available. Consult factory.

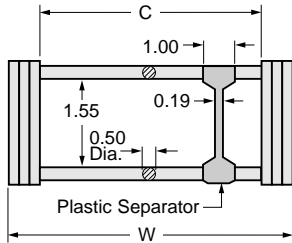

WITHOUT SEPARATOR TYPE SR

WITH SEPARATOR(S) TYPE R1^②

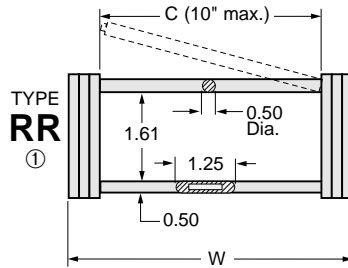

TYPE RR

①

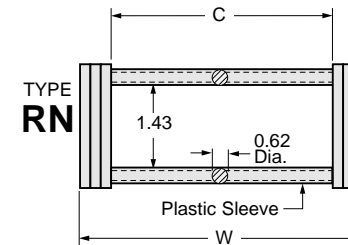

TYPE RN

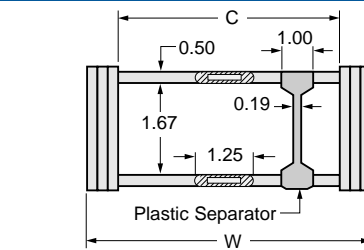

WITHOUT SEPARATOR TYPE AC

WITH SEPARATOR(S) TYPE A1^②

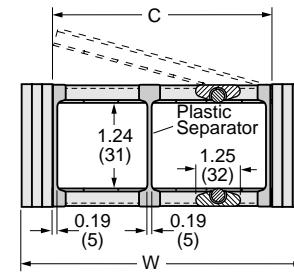

WITHOUT SEPARATOR TYPE TRB

WITH SEPARATOR TYPE TR1^②

FULLY BOLTED WITHOUT SEPARATOR TYPE RB

WITH SEPARATOR TYPE RB1^②

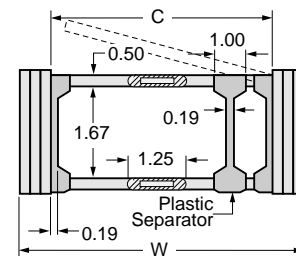

WITHOUT SEPARATOR TYPE TB

WITH SEPARATOR(S) TYPE T1^②

Dimensions in Inches

CARRIER WIDTH* C	POWERTRAK WIDTH W
4.00	5.58
6.00	7.58
8.00	9.58
10.00	11.58
12.00	13.58
14.00	15.58
16.00	17.58
18.00	19.58
Formula	C + 1.58

*Special widths available. Consult factory.

NOTES:

- Carrier type RR limited to "C" dimension no greater than 10.00".
- Numeral "1" refers to the number of vertical separators desired and must be included in the model number when ordering. For example: R1 (as above), R2 (2 separators), R3 (3 separators), etc.

NOTE:

Separators are recommended for multiple cable/hose packages to create smaller groups resulting in longer cable/hose life. Separators are adjustable and can be positioned anywhere along the carrier's width.

Mounting Brackets

Dimensions in Inches

CARRIER WIDTH C	FEET TURNED IN		FEET TURNED OUT		MTG. LOCATION G ± .12	OVER BRKTS H1	OVER BRKTS H2
	MTG. LOCATION E ± .12	F1	F2	MTG. LOCATION G ± .12			
4.00	2.00	4.82	5.28	7.57	9.31	8.84	
6.00	4.00	6.82	7.28	9.57	11.31	10.84	
8.00	6.00	8.82	9.28	11.57	13.31	12.84	
10.00	8.00	10.82	11.28	13.57	15.31	14.84	
12.00	10.00	12.82	13.28	15.57	17.31	16.84	
14.00	12.00	14.82	15.28	17.57	19.31	18.84	
16.00	14.00	16.82	17.28	19.57	21.31	20.84	
18.00	16.00	18.82	19.28	21.57	23.31	22.84	
Formula	C - 2.00	C + 0.82	C + 1.28	C + 3.57	C + 5.31	C + 4.84	

When ordering PowerTrak mounting brackets, specify end and flange arrangement (ie: Brackets both ends, flanges inward).

Foot Mounting Options

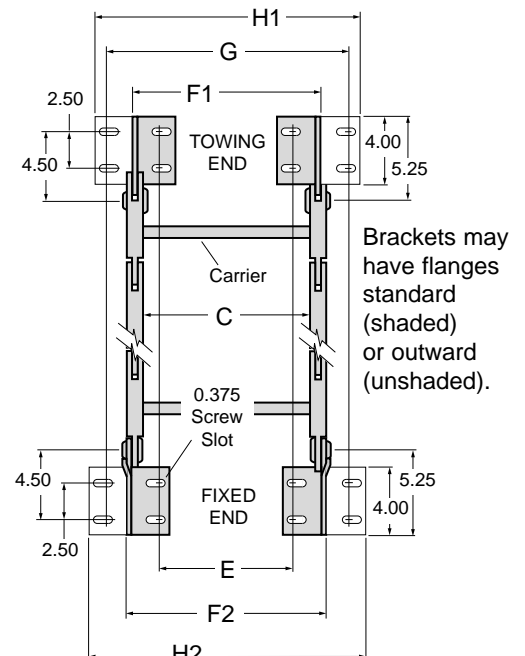
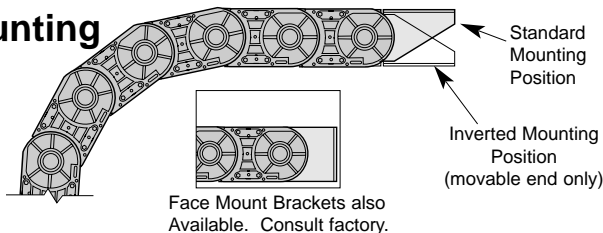

45G

GLEASON PowerTrak[®] GRP

- HEAVY DUTY DESIGN AND CONSTRUCTION
- SIDE CHAIN IS GLASS FIBER REINFORCED NYLON
- VARIETY OF CARRIER STYLES & SIZES
- RADII "A" AVAILABLE 7.22", 10.94", 14.72" & 24.04"

- TOTAL TRAVEL = 26.0 FT. (1)
- TOTAL TRAVEL W/GUIDE TRAY = 300 FT. (2)
- TOTAL TRAVEL W/GUIDE TRAY & CARRIAGE = 800 FT. (2)

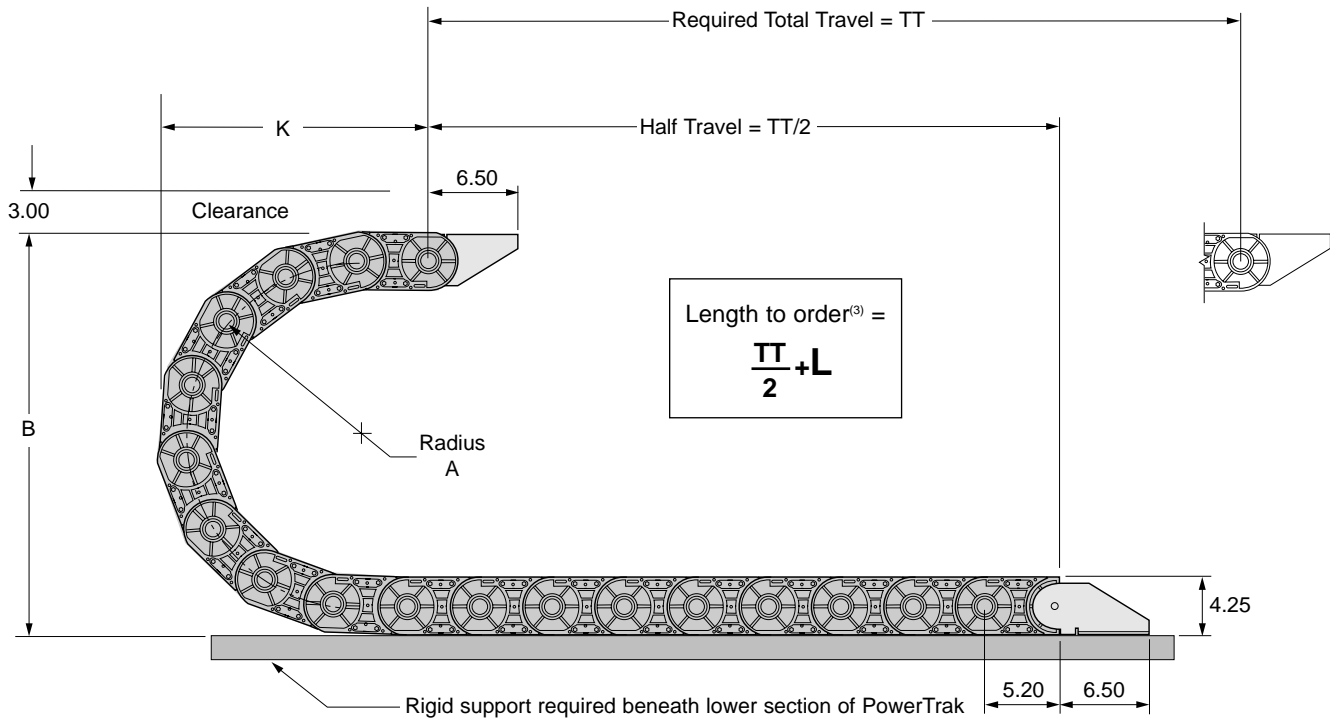

45G Dimensions

Inches unless otherwise indicated

RADIUS A	HEIGHT B	MINIMUM K	CURVE L ⁽⁴⁾
7.22	18.70	16.00	3.0 ft.
10.94	26.14	19.90	4.0 ft.
14.72	33.70	23.70	5.0 ft.
24.04	52.33	33.40	7.5 ft.

NOTES:

- (1) Total Travel is nominal, based on standard travel with cable/hose package weight of 0.5 lb/ft., and may vary with environment. GREATER TRAVELS CAN BE ACHIEVED if PowerTrak is allowed to glide within a guide tray.
- (2) GREATER TRAVELS IN TRAYS CAN BE ACHIEVED. Consult the factory.
- (3) For standard travel, i.e. two-way payout as pictured above.
- (4) L= Minimum length in FEET to form PowerTrak curve.
- (5) Indicates width in inches.

WEIGHT FORMULA, side chains and carriers only: $2.74 + (C \times 0.15) = \text{weight (lbs/ft.)}$. C = carrier width in inches.

For total weight: Trak weight (lbs/ft.) + cable/hose weight (lbs/ft.) x Trak length (ft.)

Model Number Explanation

POWERTRAK TYPE	CARRIER TYPE	RADIUS	CARRIER WIDTH ⁽⁵⁾
PT 45G	BC*	7.2	10
	BC*, AC, SR, R1, RN, A1, TB, T1, XR, XN, RB, RB1, RR**, VC, V1, VTB, VT1	7.22", 10.94", 14.72", 24.04"	6, 8, 10, 12, 14, 16, 18

*Please provide machining pattern with order for type BC carriers. **Maximum carrier width for type RR is 10".

45G Carrier Types & Dimensions

ALL DIMENSIONS IN INCHES

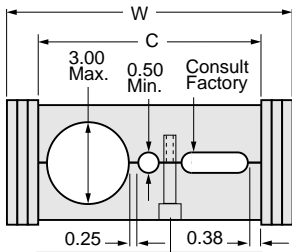

TYPE BC

Aluminum bars standard. Nylon also available. Consult factory.

If carrier width > 12.0", allow 0.5" web for central fastener.

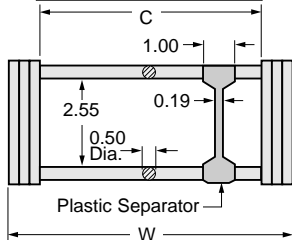

WITHOUT SEPARATOR TYPE SR

WITH SEPARATOR(S) TYPE R1^②

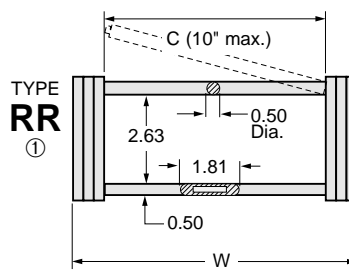

TYPE RR^①

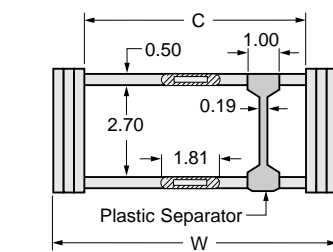

WITHOUT SEPARATOR TYPE AC & VC^③

WITH SEPARATOR(S) TYPE A1^② & V1^②

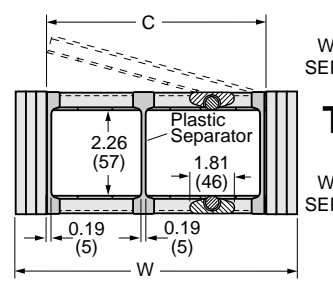

TWIST OUT WITHOUT SEPARATOR TYPE TRB

WITH SEPARATOR TYPE TR1^②
FULLY BOLTED WITHOUT SEPARATOR TYPE RB

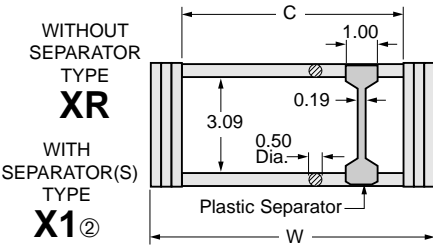

WITHOUT SEPARATOR TYPE XR

WITH SEPARATOR(S) TYPE X1^②

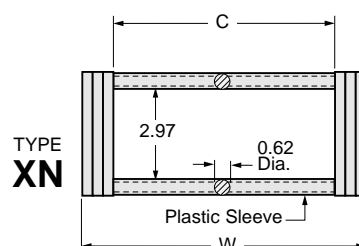

TYPE XN

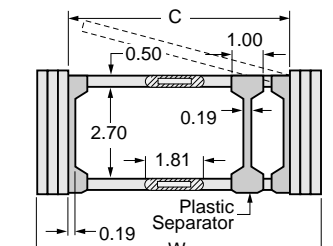

WITHOUT SEPARATOR TYPE TB & VTB^③

WITH SEPARATOR(S) TYPE T1^② & VT1^②

Dimensions in Inches

CARRIER WIDTH* C	POWERTRAK WIDTH W
6.00	7.89
8.00	9.89
10.00	11.89
12.00	13.89
14.00	15.89
16.00	17.89
18.00	19.89
Formula	C + 1.89

*Special widths available. Consult factory.

NOTES:

- Carrier type RR limited to "C" dimension no greater than 10.00".
- Numeral "1" refers to the number of vertical separators desired and must be included in the model number when ordering. For example: R1 (as above), R2 (2 separators), R3 (3 separators), etc.
- Carrier types VC and VTB to 12" wide max. Carriers over 12" in width must have at least one separator.

NOTE:

Separators are recommended for multiple cable/hose packages to create smaller groups resulting in longer cable/hose life. Separators are adjustable and can be positioned anywhere along the carrier's width.

Mounting Brackets

Dimensions in Inches

CARRIER WIDTH C	FEET TURNED IN		FEET TURNED OUT		
	MTG. LOCATION E ± .12	OVER BRKTS F1 F2	MTG. LOCATION G ± .12	H1	H2
6.00	4.25	6.90 7.52	9.64	11.45	10.83
8.00	6.25	8.90 9.52	11.64	13.45	12.83
10.00	8.25	10.90 11.52	13.64	15.45	14.83
12.00	10.25	12.90 13.52	15.64	17.45	16.83
14.00	12.25	14.90 15.52	17.64	19.45	18.83
16.00	14.25	16.90 17.52	19.64	21.45	20.83
18.00	16.25	18.90 19.52	21.64	23.45	22.83
Formula	C - 1.75	C + 0.90 C + 1.52	C + 3.64	C + 5.45	C + 4.83

When ordering PowerTrak mounting brackets, specify end and flange arrangement.

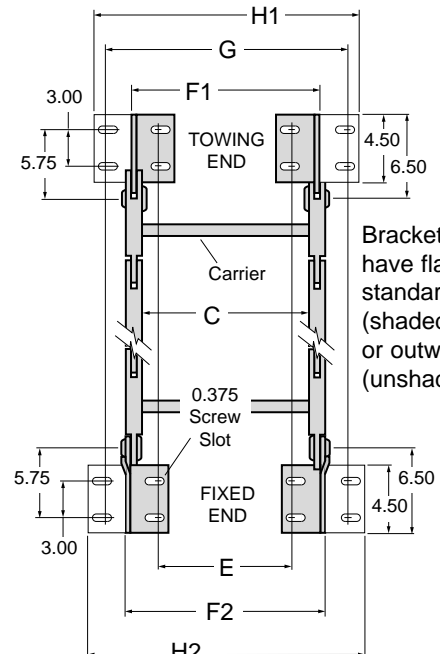

Brackets may have flanges standard (shaded) or outward (unshaded).

Foot Mounting Options

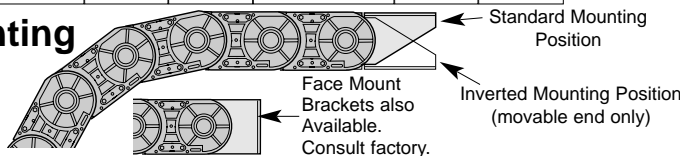

GPT-3

Guide Trays

For extended travel

Guide trays are required when recommended self-supported travel lengths are exceeded (See “Selecting” for details). This occurs when the total travel required exceeds the ability of the PowerTrak to support its own weight plus the weight of contained hoses and cables. The result is negative camber. Since nylon is a good bearing material and has an excellent memory, the negative camber is an advantage for long travels. It simply rides on itself or on a carriage. It need only be guided. See figs. 1 and 2.

The fixed end of the PowerTrak assembly is typically located at the center of its travel. When the movable end on a standard tray system is pulled past the fixed end, it rides on rollers (Fig. 1). If a carriage is used, it rides on angles because the carriage includes rollers. A carriage is recommended for high speeds and heavy loads. See following pages for carriage details.

Opposed PowerTrak units can be used if cable and hose payloads

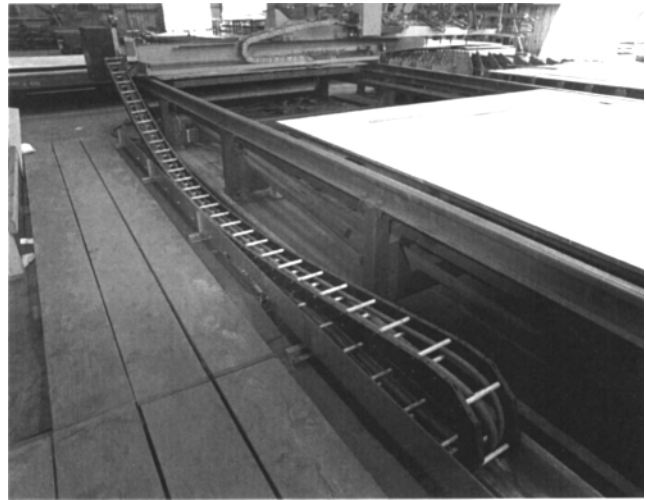

exceed the capacity of the largest model available. This divides the load or segregates hoses and cables (Figure 2).

Trays are galvanized 11 gauge steel or optional stainless steel and are open at the bottom for draining. Guide trays are available for all sizes of type “G” PowerTrak.

Standard Tray System ONE POWERTRAK

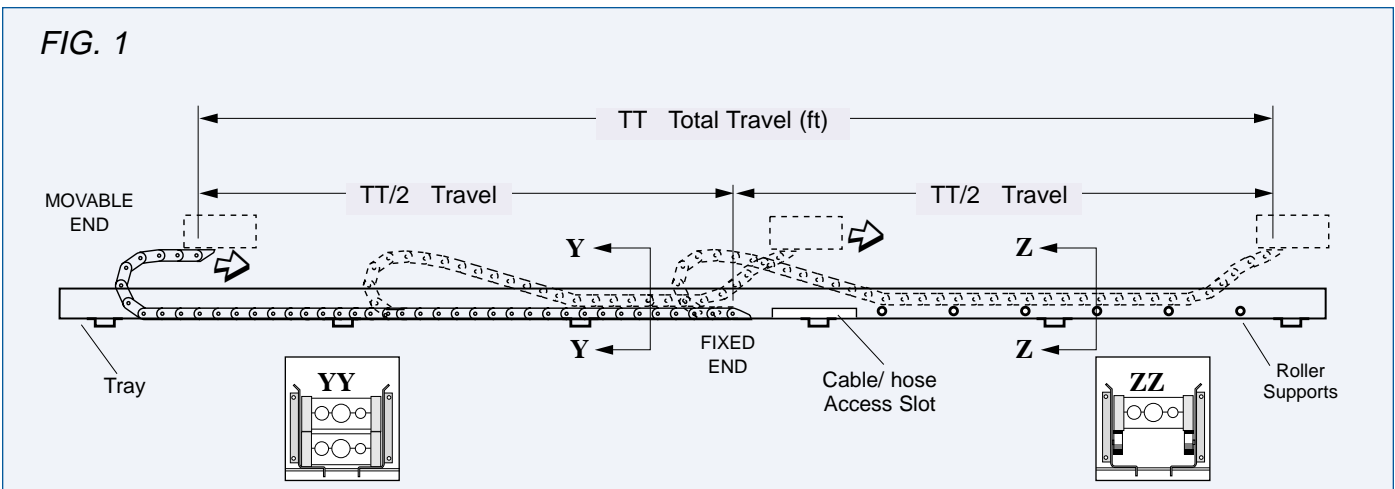

Opposed Tray System TWO POWERTRAKS

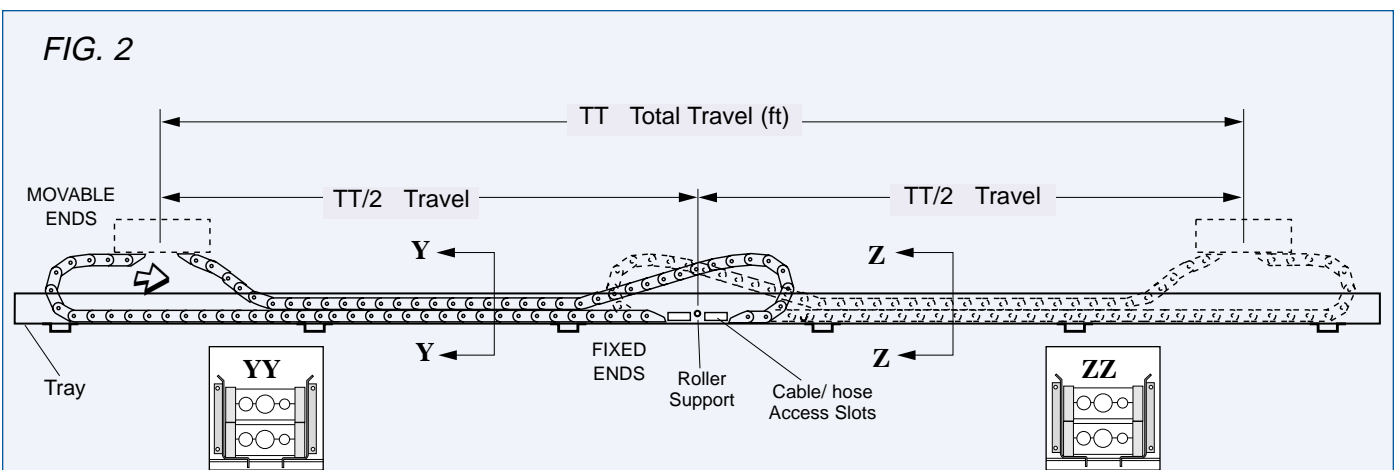

For total travels of PowerTrak exceeding 100 ft., please consult the factory.

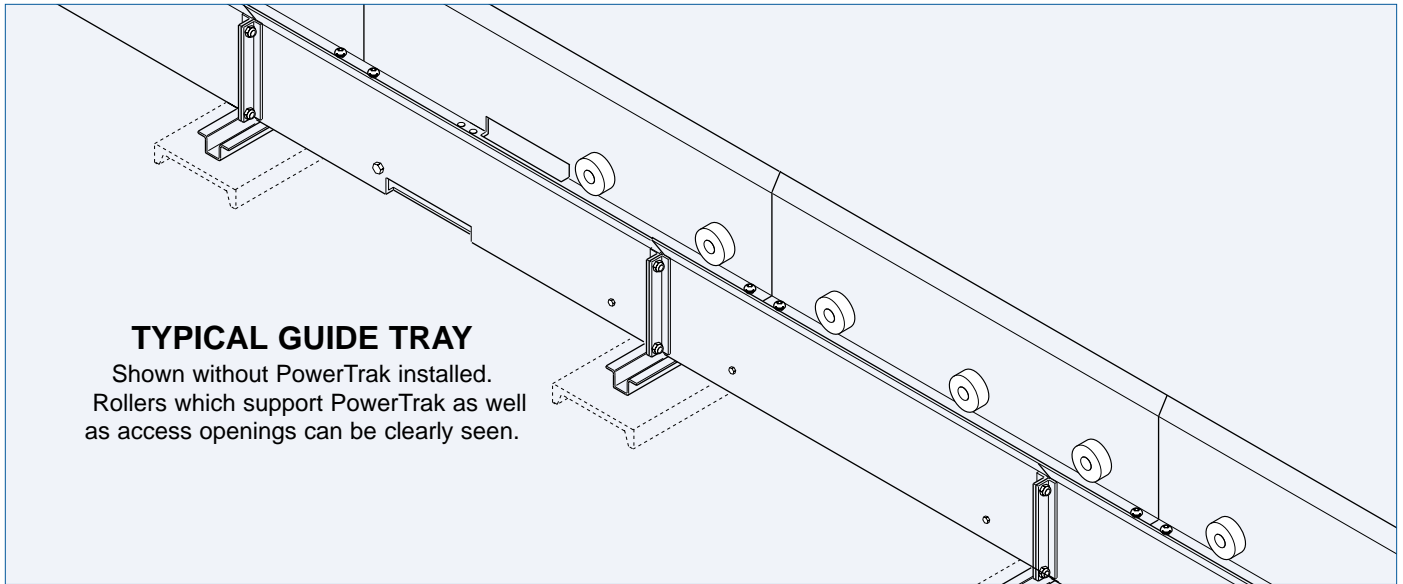

TYPICAL GUIDE TRAY

Shown without PowerTrak installed.
Rollers which support PowerTrak as well as access openings can be clearly seen.

Guide Tray

PowerTrak® Type 28G
Type 35G
Type 45G

NOTE:
Inside tray width (FF) 0.25" greater than trak width (W).

NOTE:
Traks with carrier options RR, TB, T1, XR, & XN may not be used in guide tray.

* Roller used only on single direction (standard) installation without carriage.
Angle used on single direction installation with carriage.
No supports used on opposed system.

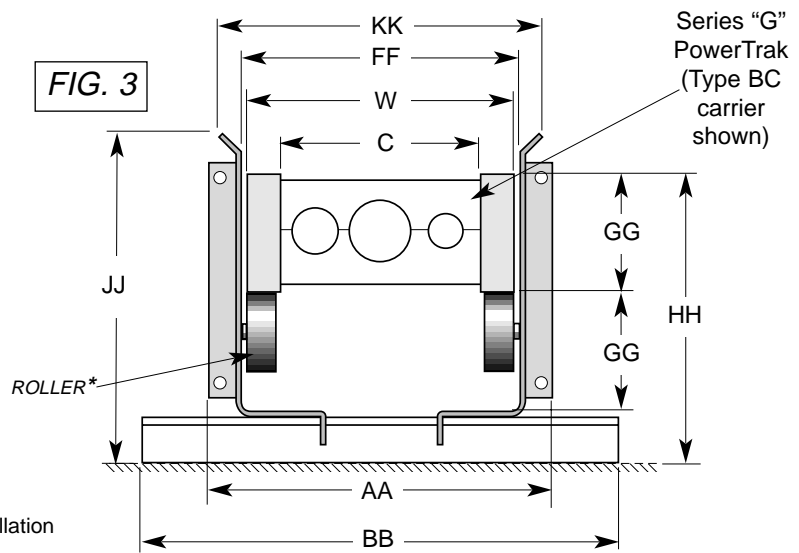

Dimensions in Inches

TYPE POWER-TRAK	C CARRIER WIDTH	W	AA	BB	FF	KK	GG	HH	JJ	TRAY LENGTH**		TRAY WEIGHT
										FIG. 1 STANDARD TRAVEL	FIG. 2 OPPOSED TRAVEL	LBS/Ft.
28G	4.00	5.34	7.65	13.38	5.59	7.18	2.69	7.00	9.00	T T + 2.0 ft.	T T + 6.0 ft.	12.4
	6.00	7.34	9.65	13.38	7.59	9.18	2.69	7.00	9.00	T T + 2.0 ft.	T T + 6.0 ft.	12.4
	8.00	9.34	11.65	13.38	9.59	11.18	2.69	7.00	9.00	T T + 2.0 ft.	T T + 6.0 ft.	12.4
	10.00	11.34	13.65	19.38	11.59	13.18	2.69	7.00	9.00	T T + 2.0 ft.	T T + 6.0 ft.	12.4
	12.00	13.34	15.65	19.38	13.59	15.18	2.69	7.00	9.00	T T + 2.0 ft.	T T + 6.0 ft.	12.4
35G	4.00	5.58	7.90	15.38	5.83	7.46	3.25	8.12	10.00	T T + 2.0 ft.	T T + 8.0 ft.	13.2
	6.00	7.58	9.90	15.38	7.83	9.46	3.25	8.12	10.00	T T + 2.0 ft.	T T + 8.0 ft.	13.2
	8.00	9.58	11.90	15.38	9.83	11.46	3.25	8.12	10.00	T T + 2.0 ft.	T T + 8.0 ft.	13.2
	10.00	11.58	13.90	15.38	11.83	13.46	3.25	8.12	10.00	T T + 2.0 ft.	T T + 8.0 ft.	13.2
	12.00	13.58	15.90	23.38	13.83	15.46	3.25	8.12	10.00	T T + 2.0 ft.	T T + 8.0 ft.	13.2
	14.00	15.58	17.90	23.38	15.83	17.46	3.25	8.12	10.00	T T + 2.0 ft.	T T + 8.0 ft.	13.2
	16.00	17.58	19.90	23.38	17.83	19.46	3.25	8.12	10.00	T T + 2.0 ft.	T T + 8.0 ft.	13.2
45G	6.00	7.89	10.21	15.38	8.14	9.77	4.25	10.12	12.00	T T + 3.0 ft.	T T + 10.0 ft.	15.2
	8.00	9.89	12.21	15.38	10.14	11.77	4.25	10.12	12.00	T T + 3.0 ft.	T T + 10.0 ft.	15.2
	10.00	11.89	14.21	15.38	12.14	13.77	4.25	10.12	12.00	T T + 3.0 ft.	T T + 10.0 ft.	15.2
	12.00	13.89	16.21	23.38	14.14	15.77	4.25	10.12	12.00	T T + 3.0 ft.	T T + 10.0 ft.	15.2
	14.00	15.89	18.21	23.38	16.14	17.77	4.25	10.12	12.00	T T + 3.0 ft.	T T + 10.0 ft.	15.2
	16.00	17.89	20.21	23.38	18.14	19.77	4.25	10.12	12.00	T T + 3.0 ft.	T T + 10.0 ft.	15.2
	18.00	19.89	22.21	23.38	20.14	21.77	4.25	10.12	12.00	T T + 3.0 ft.	T T + 10.0 ft.	15.2

**Trays supplied in 5' lengths. Round tray length UP to next 10' increment.

Carriage System

LONGER TRAVEL — HIGHER SPEEDS

The patented Gleason Carriage System supports PowerTrak throughout its entire travel length and allows longer travel and higher speeds than PowerTrak which slides on itself. Rollers reduce friction, greatly extending trak life. Reduced tow force makes it ideal for flame and laser cutters, robotic welders, and other machines requiring precision travel. Carriage may be used in Standard Travel or Opposed Travel applications. Length of carriage will be computer calculated by Gleason for your specific application. Please contact factory for additional details or a recommendation.

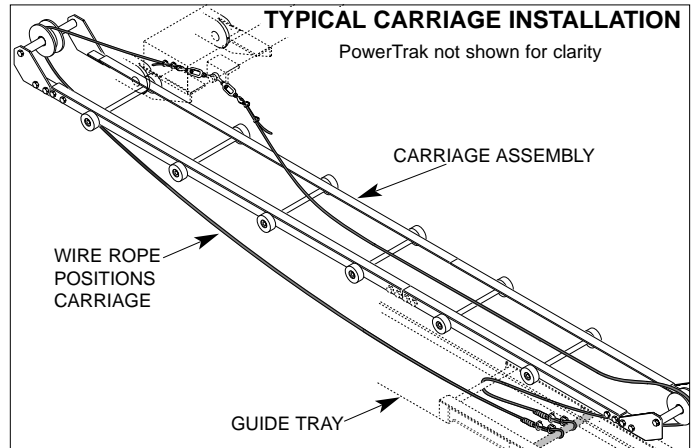

System Specifications

SYSTEM TYPE	MAXIMUM TOTAL TRAVEL	MAXIMUM SPEED	MAXIMUM ACCEL.	USE WITH POWERTRAK TYPE(S)
215G	800 FT ^①	1000 FPM	10 FPS	28G, 35G, 45G ^②

① Longer travels are possible. Consult the factory for details.

② Carriage may not be used with type RR, TB and T1(T2, T3) carriers.

215G Carriage System

DRAWING BELOW SHOWS STANDARD TRAVEL DIMENSIONS IN INCHES UNLESS NOTED

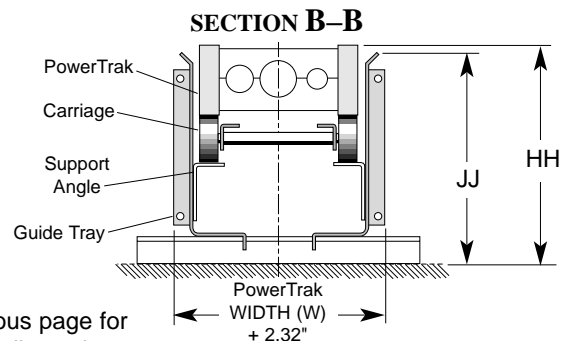
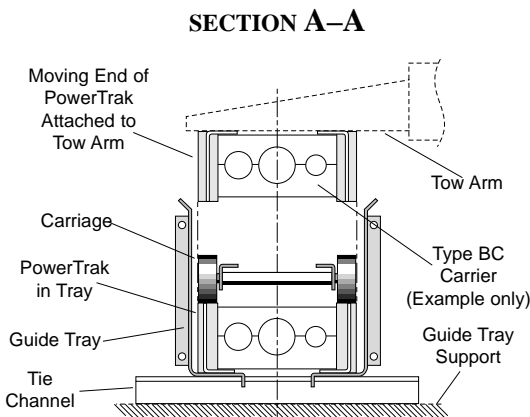
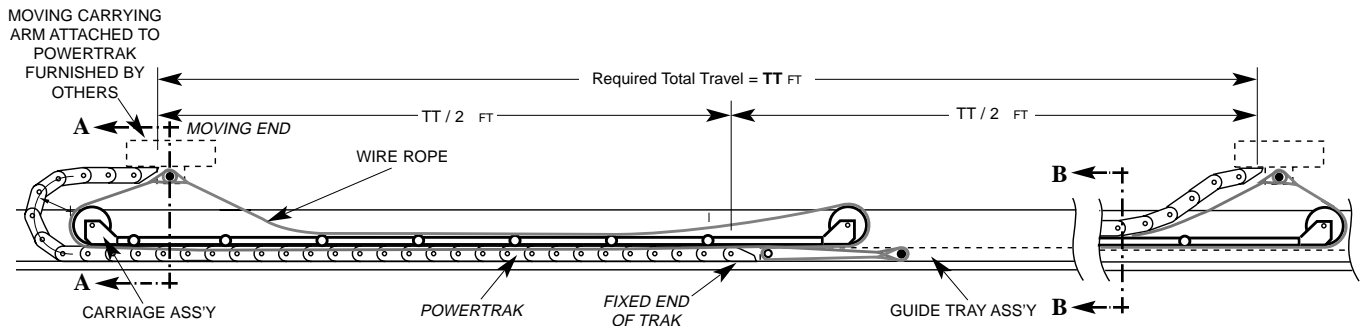

Refer to previous page for additional tray dimensions.

POWERTRAK SERIES	HH	JJ	*TRAY LENGTH		TRAY WGT. lb/ft.	CARRIAGE WEIGHT
			STANDARD TRAVEL	OPPOSED TRAVEL		
28G	9.50	9.00	TT + 5.0'	TT + 8.0'	14.20	3.4 lb/ft.+14.0 lb.
35G	10.62	10.00	TT + 5.0'	TT + 10.0'	15.20	3.6 lb/ft.+14.4 lb.
45G	12.62	12.00	TT + 6.0'	TT + 12.0'	17.00	3.8 lb/ft.+14.8 lb.

*Tray length rounded UP to next 10' increment. Factory will calculate carriage length based on total travel.

Ordering PowerTrak

BUILDING MODEL NUMBER

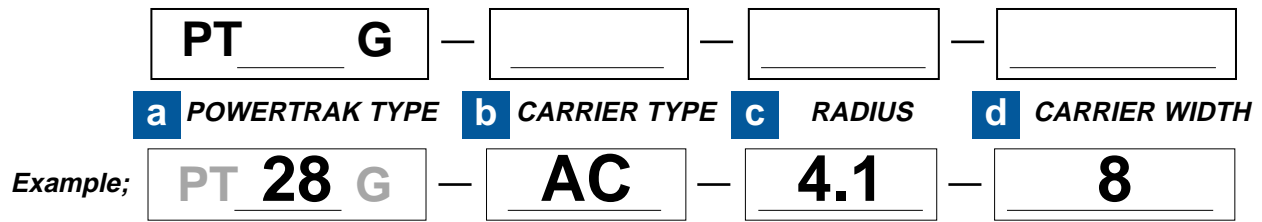

Bend radius shortened when used in model number. Example: 4.19 = 4.1.

a ENTER POWERTRAK TYPE

PowerTrak type should be suitable for the travel length required for your application and for the cable/hose package it is expected to carry. If it is not, you must choose another type PowerTrak. See specification pages for each type PowerTrak. Use of a guide tray or guide tray & carriage, if available for a given type PowerTrak, can allow increased travel. See Application pages for help calculating travel in your application and following pages for more information about your cable/hose “package”.

b ENTER CARRIER TYPE

Carrier Type should be suitable for the cable/hose package and machine duty cycle and must be available for the PowerTrak type chosen. Refer to Carrier Selection Guide and PowerTrak Specification Pages for list of carrier types available for each PowerTrak type as well as both vertical and horizontal opening dimensions.

c ENTER BEND “RADIUS”

Each PowerTrak type is available with several radii molded into the links (see PowerTrak Specification pages and Selection Guide, following page). Radius chosen should be equal to or greater than the minimum bend radius of your LEAST FLEXIBLE cable or hose. If this condition is not met, you must choose a PowerTrak type with a larger bend radius. Consult your cable/hose supplier or manufacturer for specific information if you are not sure of the bending radius of each cable or hose to be used in the PowerTrak. Or, for a working estimate, multiply the outside diameter of the largest cable or hose in the package by six (6).

d ENTER CARRIER WIDTH

Carrier width should be cable/hose package width x 1.20 (refer to Defining Cable/Hose Package) and must be compatible with PowerTrak type you have chosen. See PowerTrak Specification Pages for carrier window dimensions and compatibility with each size trak.

ADD THE FOLLOWING—Required, but not part of model number

e POWERTRAK LENGTH

NOTE: “Length to order” is computed differently if “two-way payout” is not possible. See “Applying PowerTrak” on the previous pages for details and consult a factory representative if necessary.

f OPTIONAL ACCESSORIES

Mounting brackets **are not automatically included** and must be ordered here if required. Specify type of bracket. Refer to PowerTrak Specification pages. If roller supports, guide tray or carriage are required and are available for the type PowerTrak you are ordering, also enter that information here. Compute length for guide tray as shown on previous pages. Carriage length will be calculated by factory. Carriage is never used without a guide tray.

COMPLETED EXAMPLE MODEL NUMBER



a DETERMINING POWERTRAK TYPE

Trak type must be carefully chosen to provide maximum life for both cable/hose package and trak. When selecting type, pay close attention to the following:

- A. Radius...trak must have bend radius **greater** than least flexible cable/hose bend radius (column two on guide below).
- B. Total travel...be sure total required travel does not exceed specifications for chosen trak type. See guide below.
- C. Maximum velocity of application...be sure velocity does not exceed specifications for chosen trak type. See guide below.
- D. Carrier type...although carrier type and size may not have yet been chosen, consider width of total cable/hose package (following page), as well as diameter of largest cable or hose.
- E. Choose trak type that will provide a vertical opening of sufficient size to contain cable/hose. Refer to specification pages for each trak type for more information. NOTE: On any given PowerTrak type, vertical opening varies with carrier type selected. Horizontal opening is determined by carrier width.

PowerTrak Type Selection Guide

POWERTRAK TYPE	POWERTRAK BEND RADIUS ^③	MAXIMUM TOTAL TRAVEL ^①			VELOCITY Ft/Min ^②
		NO SUPPORT	GUIDE TRAY	CARRIAGE	
PT25G	2.78, 4.95, 7.70, 11.64	14 Ft.	na	na	800 No Supt. 300 W/Tray 1000 W/Carriage
PT28G	4.19, 5.45, 6.63, 8.40	18 Ft.	300 Ft with 5 lbs/ft load	400 Ft. with 8 lbs.ft load	800 No Supt. 300 W/Tray 1000 W/Carriage
PT35G	4.94, 7.21, 10.84, 14.71	24 Ft.	300 Ft with 6 lbs/ft load	700 Ft. with 8 lbs/ft load	800 No Supt. 400 W/Tray 1000 W/Carriage
PT45G	7.22, 10.94, 14.72, 24.04	26 Ft.	300 Ft with 12 lbs/ft load	1000 Ft. with 15 lbs/ft load	800 No Supt. 500 W/Tray 1000 W/Carriage

- ① Total Travel values based upon standard travel (two-way payout) and total cable/hose weight of 0.5 lbs/ft.
- ② Speed capabilities may increase for shorter machine travels and/or light loads. Please consult the factory.
- ③ Please consult the factory concerning non-standard Bend Radii and non-standard Carrier Widths.

“SAG” is Natural!

The side links of PowerTrak Type G are made of reinforced nylon which is a good bearing material. When correctly applied, Type G PowerTrak can safely sag and is designed to glide on itself. Amount of sag depends on system length, PowerTrak type and cable/hose package weight.

- Figure 1:** A short PowerTrak with nominal sag.
- Figure 2:** Longer PowerTrak showing moderate sag.
- Figure 3:** A very long PowerTrak gliding on itself. A tray system helps guide such long systems. See “Guide Trays”.

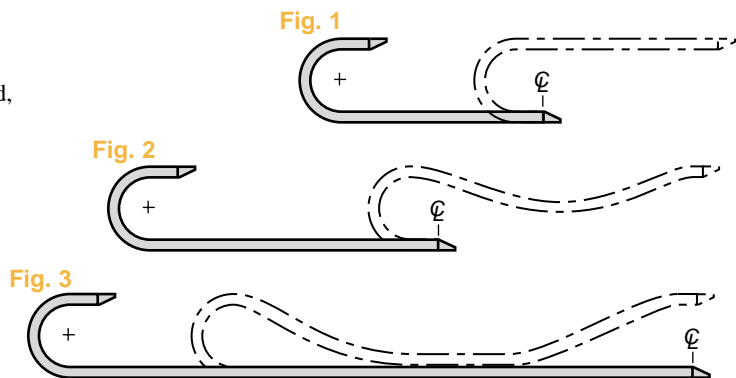

Lateral Forces

When significant lateral forces are present (on a crane bridge, for example, when the crane moves along the runway) PowerTrak may need side support. This is especially true on longer travels. A guide tray is often the solution (see “Guide Trays”). Contact us for specific recommendations.

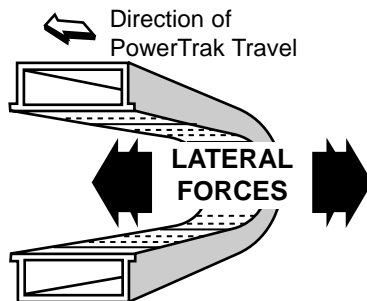

Speed

Generally, short lengths of self-supported PowerTrak can travel at high rates of speed and acceleration. For longer travels, a guide tray should be used. When speeds exceed 800 fpm and/or acceleration exceeds 10fps², please consult factory.

Ordering (continued)



DETERMINING CARRIER

Refer to selection Guide, below, and to PowerTrak Specifications pages. Use the following criteria when selecting a carrier type and width:

- A. Cable/hose package (**JQsum** and **PKG HEIGHT** from following page).
Multiply each by 1.20 to find minimum carrier length (horizontal opening) and vertical opening that should be used for your application. See Figure 1, right.
 - B. CARRIER OPTIONS page for benefits of each style carrier.
- NOTE: Style BC is most efficient design from an operational standpoint but not necessarily from a capacity standpoint. Do a careful layout.**

FIG. 1 PowerTrak Cross Section

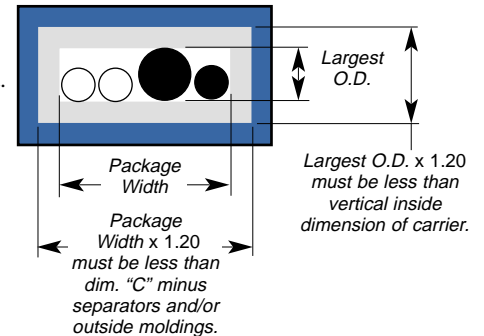

Select carrier style and size. **Selected carrier must fit PowerTrak type chosen.**
If it does not, select alternate carrier or go back and select next largest PowerTrak type.

Carrier Selection Guide

POWERTRAK TYPE	CABLE/HOSE Max O.D.	CARRIER TYPE ①	CARRIER WIDTHS ②	
			STANDARD "C"	OPTIONAL WIDTH
PT25G	1.00	BC	4, 6, 8, 10, 12	Unlimited 2"-12" ③
	0.78	SR, R1		
	0.87	AC, A1		
	0.87	TB, T1		
	0.62	RN		
	0.82	RR		
PT28G	1.35	BC	4, 6, 8, 10, 12	Unlimited 2"-12" ③
	1.04	SR, R1		
	1.09	AC, A1		
	1.09	TB, T1		
	0.88	RN		
	1.07	RR		
PT35G	1.81	BC	4, 6, 8, 10, 12, 14, 16, 18 ④	Unlimited 4"-18" ③
	1.29	SR, R1		
	1.39	AC, A1		
	1.39	TB, T1		
	1.03	RB, RB1, TRB, TR1		
	1.19	RN		
	1.34	RR		
PT45G	2.73	BC	6, 8, 10, 12, 14, 16, 18 ④	Unlimited 4"-18" ③
	2.12	SR, R1		
	2.25	AC, A1, VC, V1		
	2.25	TB, T1, VTB, VT1		
	1.88	RB, RB1, TRB, TR1		
	2.02	RN		
	2.18	RR		
	2.57	XR		
	2.47	XN		

① See page 9 for details on Carrier Types.
 ② Please consult the factory concerning non-standard Bend Radii and non-standard Carrier Widths..
 ③ PowerTraks with double or triple wide carriers are available. Do not exceed 36" overall width.
 ④ Types RB, RB1, TRB, & TR1 limited to 12" maximum width.

Special Instructions for Type BC (milled bar) Carrier

Type BC carrier uses a "split" aluminum bar which supports the cables/hoses near the true bending radius of the trak. Holes are custom machined to meet the particular application. When designing the hole layout, pay attention to the following:

1. Cables/hoses must be positioned to form a single layer with the heaviest and largest located near the PowerTrak links.
2. Determine clearance for each cable or hose as follows:
 - A. For nominal O.D.'s greater than 1.25", multiply O.D. by 1.1
 - B. For nominal O.D.'s equal to or less than 1.25", add 0.12"
3. Maintain a 0.25" space between holes to facilitate machining. If this is not possible, use a wider carrier or group two or three cables/hoses together in one horizontal slot.
4. Hoses operating at pressure greater than 200 psi should be individually contained in a vertical slot.



DEFINING YOUR CABLE/HOSE "PACKAGE"

IF YOU WISH, MAKE COPIES OF THIS PAGE FOR WORKING OR FAXING

Picture your cables and hoses as a GROUP, what we call a cable/hose "PACKAGE."

- PowerTrak should **NOT** have a radius less than the minimum bending radius of the least flexible cable or hose in your package, usually the recommended minimum bend radius of the largest cable or hose in your package (Fig 1).
- Package must fit into a PowerTrak WINDOW. Allow for at least 20% clearance. See Fig. 2 and PowerTrak Specification pages.

IMPORTANT: Information about your cables and hoses is CRITICAL for selecting the correct PowerTrak.

FIG. 1 Cable/Hose Bend Radius

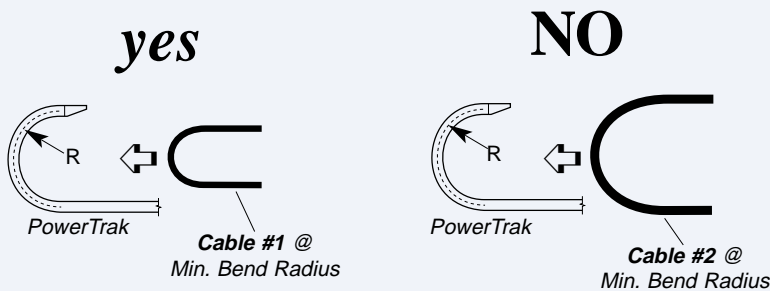

PowerTrak must have a large enough radius.

FIG. 2 PowerTrak Cross Section

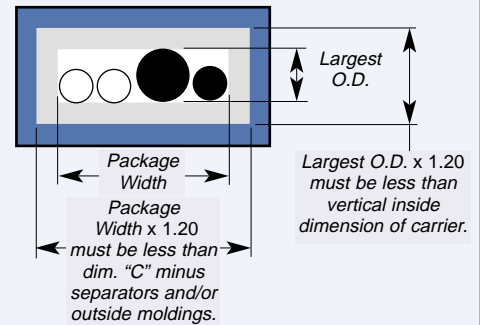

Your package must fit a window.

Fill in all of the blanks in the Worksheet below (if necessary, refer to "Cable & Hose Data" at the back of this catalog for diameters and weights of typical cables and hoses).

Cable/Hose Descrip. (Include Qty of each @ right)	J O.D.	D Min. Bend*	A Lbs/Ft	Q Quantity	AQ (A x Q)	JQ (J x Q)
_____	_____	_____	_____	_____	_____	_____
_____	_____	_____	_____	_____	_____	_____
_____	_____	_____	_____	_____	_____	_____
_____	_____	_____	_____	_____	_____	_____
_____	_____	_____	_____	_____	_____	_____
_____	_____	_____	_____	_____	_____	_____
_____	_____	_____	_____	_____	_____	_____
_____	_____	_____	_____	_____	_____	_____
_____	_____	_____	_____	_____	_____	_____

TOTAL NO. OF CABLES/HOSES (for machined bar carrier option) → **QSUM =** _____

TOTAL CABLE/ HOSE WEIGHT → **AQSUM =** _____ Lbs/ft

PKG WIDTH (Total of all O.D.s) → **JQSUM =** _____ In

PKG HEIGHT (Largest O.D. [J] of all) _____ Inches

PKG MINIMUM BEND RADIUS* _____ Inches

*PKG MINIMUM BEND RADIUS: Your package should only bend as tight as the LARGEST recommended min. bend radius of all cables or hoses in your package. Generally, but not always, the minimum bend radius is largest on your LARGEST O.D. cable/hose. Bend radius information should be available from the cable/hose manufacturer. If no information is available, a good method for determining min. bend radius of your package is to multiply your LARGEST O.D. by a factor of 6 (six): [6 x O.D.].

Ordering (continued)



DETERMINING LENGTH

You need enough PowerTrak to cover:

- The Total Travel (TT) of your machine, for one-way payout (Fig 1), or 1/2 the Total Travel, for two-way payout (fig 2).
- Plus the length to form the PowerTrak curve (L on fig. 3) from Dimension Tables, PowerTrak Specification pages).

The most cost-effective way to use PowerTrak is to locate the trak's fixed end (cable/hose source) at the CENTER of the machine travel, allowing pay-out in two (2) directions. We refer to this as "Two-way payout", illustrated in figure 4. Travel potential for the same length PowerTrak is DOUBLED when two-way payout is used. In the same way, you minimize the cost of cables and hoses – they need be only about HALF as long as your total travel (TT).

Opposed Travel application (Fig 4) does not shorten the length of PowerTrak required on each side (both must be 1/2 total travel). Rather, an Opposed Travel application is two similar PowerTraks installed in opposite directions. This application may allow use of a smaller trak type, shorter carriers or a single-wide rather than double-wide trak configuration. An opposed travel application also allows for distinct separation of cable and hoses.

ONE-WAY PAYOUT	TT (ft.)+L(ft.)	Length to order:	TWO-WAY PAYOUT	$\frac{TT(ft.)}{2} + L(ft.)$
---------------------------	------------------------	---------------------------------	---------------------------	--

FIG. 1

**STANDARD travel
with
ONE-WAY payout**

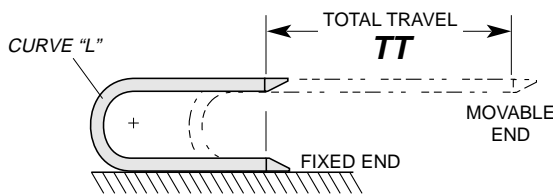

FIG. 2

**STANDARD travel
with
TWO-WAY payout**

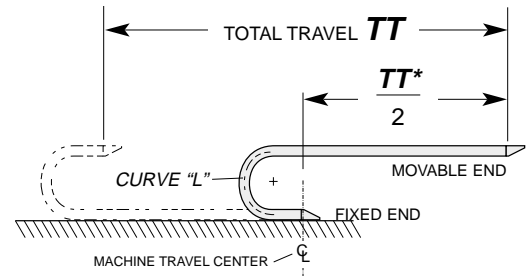
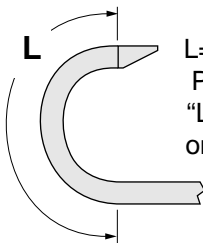

FIG. 3



L= Minimum length to form PowerTrak curve. Obtain "L" from Dimension Tables on pages 10, 12, 14 or 16.

FIG. 4

**OPPOSED travel
with
TWO-WAY payout**

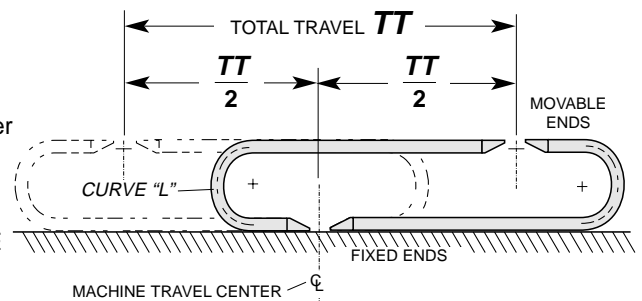

On OPPOSED TRAVEL applications, length of trak **must be identical** for both PowerTraks. Style of carrier, including number of dividers, may differ between the two PowerTraks so as to accommodate different cable and hose arrangements. For long travels, use of a GUIDE TRAY is highly recommended. Use of a CARRIAGE is also recommended but not essential. If GUIDE TRAY is used, trak link style and carrier lengths must also be identical for the two PowerTraks.

Optional Accessories

Roller Supports

Roller supports are mounted in a stationary position to increase the total travel capability of PowerTrak. When a given PowerTrak type will not handle the total weight of your cables and hoses when self-supported, adding one or two support rollers may solve the problem.

See “Adding Roller Supports” in “Applying type “G” PowerTrak” for support application. Roller supports are not recommended for use with Types 25G & 28G.

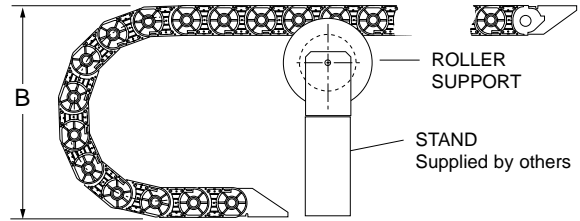

PART NUMBER	CARRIER WIDTH C	A	D	E
090166	4.00	7.63	14.63	13.13
090167	6.00	9.63	16.63	15.13
090168	8.00	11.63	18.63	17.13
090169	10.00	13.63	20.63	19.13
090170	12.00	15.63	22.63	21.13
090171	14.00	17.63	24.63	23.13
090172	16.00	19.63	26.63	25.13

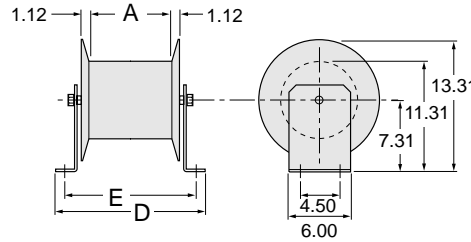

HEIGHT OF STAND (stand supplied by others)
 may be calculated using the formula:
 $B = (\text{Link Height} + 11.31)$
 B = PowerTrak Height
 See “Dimensions” tables (pages 12, 14, & 16) for “B” and Link Height for each type and radii PowerTrak.

Chip Covers

Stainless steel chip covers on both sides of the PowerTrak protect cable and hoses against hot chips and mechanical damage. For use in standard, opposed and combination travel configurations only. May be used with optional roller supports.

Not intended for long travels using guide tray or carriage. Please consult factory for recommendations.

Other Options:

- Stainless steel hardware, nuts, bolts, and washers.
- Hard coated anodized aluminum carriers.
- Splice kits.

Cable/hose Anchor Clamps

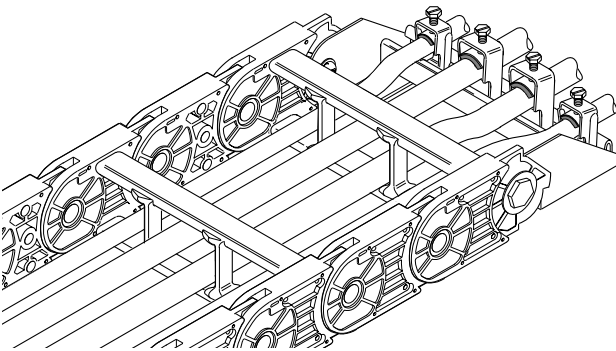

- *Affixes hoses or cables at ends of trak to prevent undue wear or stress.**
 - *Seven sizes, for hose or cable 0.38" to 2.12" O.D.*
 - *Rugged zinc plated steel for long life.*
 - *Heavy duty steel mounting bracket.*
 - *All clamps fit one mounting bracket. Simply attach proper size clamp when changing cable.*
- * Clamps not recommended for *fixed* end on long trak runs in guide tray. Use bar clamp in this application.

Heavy Duty Cable/hose Tie Bracket

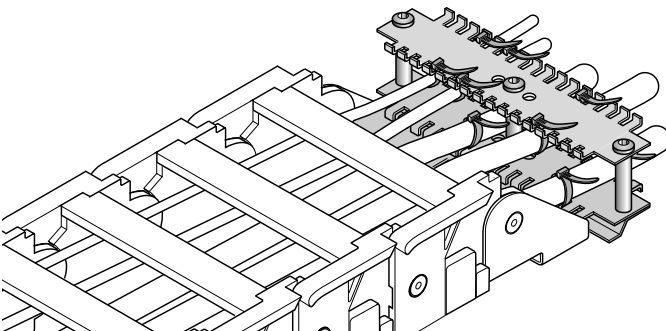

- *Affixes hoses or cables at ends of trak to prevent undue wear or stress.*
- *Dual tie system holds more securely than single ties. Ties not included.*
- *Ideal system when two layers of cables/hoses are used in PowerTrak.*
- *Rugged baked polyester finished steel with zinc plated hardware.*

Consult factory for sizes, model numbers and more details on these and other cable/hose securing brackets.

Material Data

PowerTrak Side Chains

MATERIAL :

Molded fiber-glass reinforced virgin nylon (polyamide).
Standard color is black.

MECHANICAL PROPERTIES:

1. Specific gravity-1.37
2. Tensile strength-25,500 psi (DAM)*/17,000 psi (RH50)**
3. Flex modulus-1,100,000 psi (DAM)/760,000 psi (RH50)
4. Deflection temperature @ 264 psi-420 degrees F.
5. Izod impact @ 73 degrees F.-2.5 ft-lbs/in (DAM)
6. Elongation @ 73 degrees F.-2.0% (DAM)
7. Shear strength-12,000 psi (DAM)

* DAM = Dry-as-molded condition

** RH50=Moisture conditioned to equilibrium at 50% Relative Humidity

WATER ABSORPTION (by weight):

1.1% in 24 hours

DIELECTRIC STRENGTH:

530 volts/mil (DAM)

CONTINUOUS OPERATING TEMPERATURE:

Deviation from ambient temperature range of +50°F to +90°F requires special consideration. Allowable ambient temperature range: -10°F or +250°F.

FLAMMABILITY RATING:

UL94-HB

ULTRAVIOLET RADIATION RESISTANCE:

Very good due to carbon black color additive (black color only)

GAMMA RADIATION RESISTANCE:

10 megarads total dosage at 85% retention of mechanical properties

CHEMICAL RESISTANCE:

1. Unaffected by lubricating oils & greases, aliphatic & aromatic hydrocarbons, including conventional fuels
2. Resistant to variety of paints & lacquers, detergents, aerosol preparations, food products containing animal or vegetable fats, organic compounds (such as aldehydes, ketones, monohydroxyl alcohols, most esters, chlorinated aliphatic and aromatic materials). Some of these compounds will be absorbed and cause reduction in mechanical strength.
3. Affected by phenols, formic acid, trichloroacetic acid, fluoroalcohols, organic acids, acetic and strong acids.
4. Temperature, chemical concentration, time and stress levels all affect service life in a chemical environment.

CORROSION RESISTANCE:

Unaffected by salt water and hard water

- A. Prolonged exposure in water will plasticize the material to increase impact strength and reduce tensile strength
- B. Unaffected by electrolytic corrosion

WEATHERABILITY:

Resistant to molds, bacteria and fungi.

PowerTrak Carrier Styles VC, V1, VTB, VT1

MATERIAL :

Black, Exterior Grade, Rigid PVC extrusion compound.

MECHANICAL PROPERTIES:

1. Specific gravity - 1.45
2. Tensile strength - 6,600 psi
3. Tensile modulus - 435,000 psi
4. Flexural Strength - 11,200 psi
5. Flexural Modulus - 410,000 psi
6. Deflection temperature @ 264 psi - 160 degrees F.
7. Notched Izod Impact @ 73 degrees F. - 15 ft-lbs/in
8. Shore D Hardness - 79

WATER ABSORPTION (by weight):

0.4% in 24 hours

DIELECTRIC STRENGTH:

400 volts/mil

CONTINUOUS OPERATING TEMPERATURE:

-20°F to +140°F.

FLAMMABILITY RATING:

UL94 V-0

ULTRAVIOLET RADIATION RESISTANCE:

Very good due to carbon black colorant

CHEMICAL RESISTANCE:

1. Unaffected by hard or soft water, household chemicals, and waste water.
2. Resistant to petroleum-based chemicals, paint, and organic compounds.

WEATHERABILITY:

Resistant to molds, bacteria and fungi.

Cable & Hose Data

TYPE SO CABLE — 600 VOLT

16 AWG			14 AWG			12 AWG			10 AWG		
No. Cond.	Dia. In.	Weight lb/ft	No. Cond.	Dia. In.	Weight lb/ft	No. Cond.	Dia. In.	Weight lb/ft	No. Cond.	Dia. In.	Weight lb/ft
2	0.374	0.094	2	0.512	0.158	2	0.586	0.204	2	0.638	0.250
3	0.393	0.110	3	0.538	0.184	3	0.616	0.244	3	0.671	0.310
4	0.427	0.144	4	0.584	0.224	4	0.668	0.282	4	0.730	0.371
5	0.510	0.156	5	0.665	0.260	5	0.725	0.322	5	0.796	0.425
6	0.565	0.178	6	0.710	0.302	6	0.805	0.380	6	0.883	0.485
7	0.605	0.202	7	0.710	0.329	7	0.865	0.435	7	0.982	0.593
8	0.645	0.222	8	0.770	0.373	8	0.920	0.475	9	1.127	0.725
9	0.720	0.268	9	0.820	0.414	9	1.020	0.550	10	1.127	0.760
10	0.720	0.278	10	0.885	0.434	10	1.020	0.581	12	1.153	0.850
12	0.740	0.305	12	0.905	0.481	12	1.050	0.645	20	1.455	1.400
14	0.775	0.348	14	1.000	0.556	14	1.105	0.743	24	1.595	1.645
16	0.825	0.386	16	1.050	0.657	16	1.160	0.840	26	1.595	1.740
18	0.860	0.430	18	1.110	0.715	18	1.227	0.925	28	1.725	1.880
20	0.900	0.466	20	1.150	0.785	20	1.287	1.005	32	1.830	2.180
22	0.940	0.503	22	1.210	0.857	22	1.370	1.140	36	1.890	2.400
24	1.015	0.564	24	1.320	0.920	24	1.443	1.225	40	2.030	2.660
26	1.015	0.604	26	1.350	0.986	26	1.443	1.290	44	2.115	2.890
28	1.070	0.654	28	1.370	1.098	28	1.523	1.400	48	2.150	3.100
30	1.070	0.677	30	1.390	1.138	30	1.523	1.450	52	2.200	3.330
32	1.120	0.714	32	1.450	1.220	40	1.820	1.990	56	2.275	3.550
34	1.155	0.807	34	1.495	1.300	44	1.900	2.140			
36	1.155	0.820	36	1.515	1.359	48	1.930	2.300			
40	1.235	0.881	40	1.550	1.429	52	1.980	2.450			
44	1.280	0.940	44	1.715	1.619	56	2.020	2.600			
48	1.290	0.995	48	1.740	1.734	60	2.090	2.780			
52	1.360	1.100	52	1.784	1.843						
56	1.410	1.170	56	1.865	2.030						
60	1.465	1.260	60	1.925	2.156						

TYPE W CABLE — 600 VOLT

AWG Size	No. Cond.	Dia. In.	Weight lb/ft
8	2	0.788	0.328
	3	0.894	0.470
	4	0.966	0.583
6	2	0.872	0.425
	3	0.983	0.614
	4	1.068	0.769
4	2	1.040	0.780
	3	1.068	0.797
	4	1.166	1.019
3	2	1.033	0.687
	3	1.135	0.950
	4	1.241	1.197
2	2	1.177	0.888
	3	1.244	1.152
	4	1.326	1.429
1	2	1.365	1.090
	3	1.413	1.491
	4	1.548	1.877
1/0	2	1.454	1.386
	3	1.539	1.805
	4	1.686	2.309
2/0	2	1.555	1.640
	3	1.647	2.154
	4	1.807	2.738

TYPE G-GC CABLE — 600 VOLT

AWG Size	No. Cond.	Dia. In.	Weight lb/ft
8	3	0.915	0.661
6	3	1.000	0.792
4	3	1.120	1.088
3	3	1.180	1.250
2	3	1.250	1.436
1	3	1.440	1.856
1/0	3	1.565	2.270
2/0	3	1.630	2.660

Refer to the National Electric Code for ampere ratings and other details.

Whenever possible, refer to specific manufacturer's information regarding cable or hose. If this information is not available, these charts are composites and may be used as guides to typical cable and hose size and weights.

HOSE GENERAL PURPOSE	I.D. In.	Braid	O.D. In.	PSI (WORKING)	Weight lb/ft
	Listings for general purpose hose do NOT include fluid weight. Specific fluid weights should be added when figuring Total Cable/Hose Weight.	.25	2	0.59	250
	.38	2	0.72	250	0.18
	.50	2	0.84	250	0.23
	.75	2	1.16	250	0.37
	1.00	2	1.50	150	0.64
	1.25	2	1.75	150	1.01
	1.50	2	2.00	150	1.06

HOSE SINGLE HYDRAULIC	I.D. In.	Braid	O.D. In.	PSI (WORKING)	Weight lb/ft
	Listings for single hydraulic hose do NOT include fluid weight. Specific fluid weights should be added when figuring Total Cable/Hose Weight.	.25	2	0.58	5000
	.38	2	0.73	4000	0.35
	.50	2	0.86	3500	0.42
	.75	2	1.14	2250	0.60
	1.00	2	1.48	2000	0.89
	1.25	2	1.87	1625	1.40

Cable Management

Since 1911 Gleason Reel Corp. has been in the business of CABLE MANAGEMENT. Our products are designed to convey and protect valuable cables and hoses that power and control moving machines of all types. They improve productivity and safety on the job by moving cables and hoses away from hazardous locations on machinery or the shop floor into a controlled environment. Whether you choose Reels for efficient storage and payout from virtually any angle, Festoon Systems for overhead applications or PowerTrak® for protection on machinery in motion, your cables and/or hoses will last longer and provide better service with a cable management system from **Gleason Reel Corp. ...**

...The Cable & Hose Management Company!



In addition to three types of PowerTrak, one of which is detailed in this catalog, Gleason manufactures a complete line of motor or spring driven and hand operated cable and hose reels in a wide variety of sizes as well as I-beam, c-rail and wire rope supported festoon systems for handling cables or hoses overhead. Contact Gleason Reel Corp. or your local Gleason Representative.



Gleason Reel Corp.

P.O. Box 26 • 600 South Clark St.
Mayville, Wisconsin 53050-0026
Phone 920-387-4120 • FAX 920-387-4189
www.hubbell-gleason.com