

Series 21/22

- Up to 1270 PPR with marker
- Compact 2.25" cube shape
- Economical design



APPLICATION/INDUSTRY

The Series 21/22 QUBE encoder is designed for application in industrial environments, and is stable in temperatures from 0 to 70°C.

- Measuring, cut-to-length or size for textile, metal, lumber and rubber industries
- Tracking, storage & retrieval, pick & place, conveying, and elevating for material handling applications
- Winding, including films, foils, wire and extrusions
- Measuring mechanical motion for processing, labeling, filling, mixing, batching, and packaging
- Position control, for flexible and automatic assembly equipment
- Speed feedback, for precise drive and machine monitoring and control

DESCRIPTION

The Series 21/22 QUBE generates digital incremental position data proportional to shaft rotation. Through higher mechanical and electronic operating speeds, the Series 21/22 QUBE can boost system speeds, cycle times, and productivity.

Its general-purpose design makes the Series 21/22 QUBE compatible with most programmable controllers, electronic counters, motion controllers, and motor drives. The Series 21/22 QUBE is electrically and physically interchangeable with most cube-style encoders on the market. It can easily be applied with belts and pulleys, leadscrews, rack and pinions, lineshafts, etc..

FEATURES AND BENEFITS

Mechanical and Environmental Features

- Environmentally sealed enclosure
- Large 3/8", 1/4" or 6 mm diameter stainless steel shafts
- Durable anodized aluminum housing with 5/16" thick housing walls
- Extra-wide bearing span with heavy-duty sealed bearings front and rear
- 6000 RPM capability

Electrical Features

- Wide selection of resolutions up to 1270 PPR
- Wide input voltage range eliminates the need for multiple models
- Unidirectional or quadrature outputs
- Optional complementary (differential) outputs

SPECIFICATIONS

STANDARD OPERATING CHARACTERISTICS

Code: Incremental
 Resolution: 1 to 1270 PPR (pulses/revolution)
 Accuracy: (Worst case any edge to any other edge) ±2.5 arc-min.
 Format: Two channel quadrature (AB) with optional Index (Z) and complementary outputs
 Phase Sense: A leads B for CW shaft rotation as viewed from the shaft end of the encoder farthest from the connector or cable
 Quadrature Phasing: 90° ± 18° electrical
 Symmetry: 180° ± 18° electrical
 Index: 225° ± 90° electrical (active high)
 Waveforms: Squarewave with rise and fall times less than 1 microsecond into a load capacitance of 1000 pF

ELECTRICAL

Input Power:
 4.5 min. to 26 VDC max. at 110 mA max., not including output loads
 Outputs:
 7273 Open Collector: 30 VDC max., 40 mA sink max.
 7272 Push-Pull and Differential Line Driver: 40 mA sink or source
 Frequency Response: 120 kHz min. data, 50 kHz min. Index
 Electrical Protection: Overvoltage, reverse voltage and output short circuit protected
 Noise Immunity: Tested to EN50082-2 (Heavy Industrial) for Electro Static Discharge, Radio Frequency Interference, Electrical Fast Transients, Conducted and Magnetic Interference

CONNECTIONS

Mating Connector:
 6 pin, style MS3106A-14S-6S (MCN-N4)
 7 pin, style MS3106A-16S-1S (MCN-N5)
 5 pin, style M12: Cable with connector available
 8 pin, style M12: Cable with connector available

MECHANICAL

Shaft Loading: 40 lbs. radial, 30 lbs. axial
 Shaft Speed: 6,000 RPM max.
 Shaft Tolerance: Nominal -0.0003"/-0.0007"
 Starting Torque: 2.5 oz-in max.
 Moment of Inertia: 1.3 x 10⁻⁴ oz-in-sec²
 Weight: 14 oz. max.

ENVIRONMENTAL

Operating Temperature: 0 to +70°C;
 Storage Temperature: -40 to +90°C
 Enclosure: Environmentally sealed

ELECTRICAL CONNECTIONS

MS Connector Accessory Cables - when Code 4= 0 to 4

Table 1 – Current Sink Output

Pin	Function	Wire Color Code	Cable Acc'y #14006070010 Color Code
A	Common	BLK	BLK
B	Power Source	RED	RED
C	Case (Ground)	GRN/BLK	GRN
D	Signal A	GRN	BRN
E	Signal B	ORN	ORN
F	Supply Common	BLK	BLK

Table 2 – 7 Pin Line Driver Output

Pin	Function	Wire Color Code	Cable Acc'y #14004310010 Color Code
A	Signal A	GRN	RED
B	Signal B	ORN	BLU
C	Signal A	RED/BLK	YEL
D	Power Source	RED	WHT
E	Signal B	WHT/BLK	GRN
F	Common	BLK	BLK
G	Case (Ground)	GRN/BLK	

Table 3 – Current Sink Output w/Marker

Pin	Function	Wire Color Code	Cable Acc'y #108241-0010 Color Code
A	Common	BLK	BLK
B	Power Source	RED	RED
C	Signal Z	WHT	GRN
D	Signal A	GRN	BRN
E	Signal B	ORN	ORN
F	Common	BLK	BLK

Table 4 – 6-Pin Line Driver

Pin	Function	Wire Color Code	Cable Acc'y #14006640010 Color Code
A	Common	BLK	BLK
B	Power Source	RED	RED
C	Signal A	GRN	BRN
D	Signal A	RED/BLK	BRN/WHT
E	Signal B	ORN	ORN
F	Signal B	WHT/BLK	ORN/WHT

Table 5 – Cable termination Line Driver Output with Marker

Function	Wire Color Code
Signal A	GRN
Signal B	ORN
Signal Z	WHT
Power Source	RED
Supply Common	BLK
Case (Ground)	GRN/BLK
Signal A	RED/BLK
Signal B	WHT/BLK
Signal Z	BLU

Cable Configuration: PVC jacket, 105 °C rated, overall foil shield; 3 twisted pairs 26 AWG (output signals), plus 2 twisted pairs 24 AWG (input power)

5 & 8 Pin M12 Accessory Cables - when Code 4= 5 to 9 and A

Connector pin numbers and cable assembly wire color information is provided here for reference.

Encoder Function	Table 6 5 Pin Single Ended		Table 7 8 Pin Single Ended		Table 8 8 Pin Differential	
	Pin	Wire Color	Pin	Wire Color	Pin	Wire Color
Sig. A	4	BLK	1	BRN	1	BRN
Sig. B	2	WHT	4	ORG	4	ORG
*Sig. Z	5	GRY	6	YEL	6	YEL
Power +V	1	BRN	2	RED	2	RED
Com	3	BLU	7	BLK	7	BLK
Sig. A	–	–	–	–	3	BRN/WHT
Sig. B	–	–	–	–	5	ORG/WHT
*Sig. Z	–	–	–	–	8	YEL/WHT

* Index not provided on all models. See ordering information

Cable Configuration: PVC jacket, 105 °C rated, overall foil shield; 24 AWG conductors, minimum

See "Accessories" Section for Connectors and Cable Assemblies Ordering Information

DIMENSIONS

Series 21/22

MS Connector Models

Approximate Dimensions (in inches)

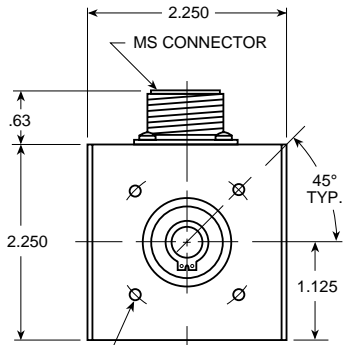

6-32 UNC-2B THREADS x .187 DEEP ON 2.00 DIA. B.C., 4 HOLES ON 3 FACES (FRONT, REAR & BOTTOM).
FOR MODELS 22M ONLY: M3 x 0.5^{RH} THREADS x 5mm DEEP ON A 50.8mm DIA. B.C. ON (3) FACES

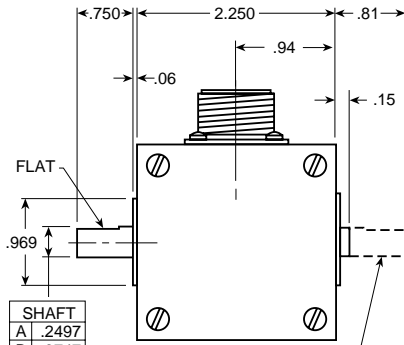

SHAFT	
A	.2497
B	.3747
C	6 mm

OPTIONAL DOUBLE-ENDED SHAFT

Prewired Cable Models

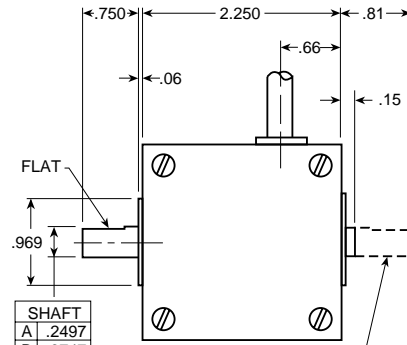

SHAFT	
A	.2497
B	.3747
C	6 mm

OPTIONAL DOUBLE-ENDED SHAFT

M12 Connector Models

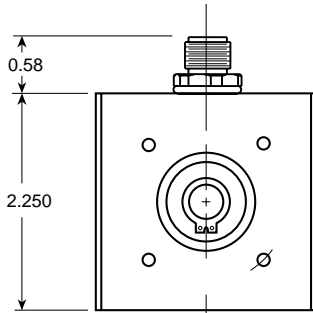

ORDERING INFORMATION

Series 21/22

INDUSTRIAL

Code 1: Model		Code 2: Pulses/Rev		Code 3: Mechanical		Code 4: Output		Code 5: Electrical		Code 6: Termination	
□ □ □		□ □ □ □		□		□		□		□	
Ordering Information											
21	Qube Encoder, Unidirectional	0001	0150	0	3/8" Double Ended Shaft	0	Single Ended, Table 1	available when Code4 = 0, 1, 5, 6, 7 or 8:		0	MS Connector
		0002	0180			2	Differential, Table 2	0 5-26 VDC in, 5-26 VDC Open Collector w/2.2k pull-ups out		1	18" Cable
22	Qube Encoder, Bidirectional	0003	0192	1	3/8" Single Ended Shaft	available only when code 6 is 0:		1 5-26 VDC in, 5-26 VDC Open Collector w/o pull-up out		2	3' Cable
		0004	0200			4 Differential, Table 4		2 5-26 VDC in, 5V Totem Pole out		3	6' Cable
		0005	0250	2	1/4" Double Ended Shaft	available only when Code 1 is 22 or 22M:		3 5-26 VDC in, 5V Line Driver out		4	10' Cable
		0006	0256			1 Single Ended, with Index, Table 3		4 5-26 VDC in, 5-26 VDC Line Driver		5	15' Cable
22M	Metric Qube Encoder, Bidirectional	0007	0300	3	1/4" Single Ended Shaft	available when Code 1 = 22M:				6	M12 Connector
		0008	0360			4 6mm Double Ended Shaft					
		0009	0400			5 6mm Single Ended Shaft					
		0010	0480			available only when Code 6 is 1 to 5:					
		0012	0500			3 Differential, with Index, Table 5					
		0015	0512			available only when Code 6 is 6:					
		0018	0600			5 5 pin M12 connector, single ended, no index, Table 6					
		0020	0720			6 5 pin M12 connector, single ended, with index, Table 6					
		0025	0800			7 8 pin M12 connector, single ended, no index, Table 7					
		0030	0900			8 8 pin M12 connector, single ended, with index, Table 7					
		0050	1000			9 8 pin M12 connector, differential, no index, Table 8					
		0060	1024			A 8 pin M12 connector, differential, with index, Table 8					
		0100	1200								
		0120	1250								
		0125	1270								