



IP80 Series Flow Sensor Instructions

General Information

The IP80 Series are impeller-type insertion meters designed for use in pipe sizes 1/2" to 8". High-quality jewel bearings and nickel-bound tungsten carbide shaft are used for maximum life and extreme low friction. Bodies are machined from solid rod for maximum precision. Low-flow performance is superior. The rotation of the rotor is detected by a non-drag Hall-effect sensor. Output is a pulse-type square wave, which can be sent long distances (up to 2,000 feet) without a transmitter. This signal can be connected directly to SeaMetrics controls, as well as PLC's, counters, and computer cards.

SeaMetrics IP meters are ideal for chemical proportioning applications. If no display is required, a simple divider such as the PD10 provides adjustable pump pacing. For rate and total display, as well as pump pacing, the FT415/420 flow indicator can be mounted directly on the IP80 Series, or remotely on a wall or panel.

The IP80 Series require special fittings, since they are not depth-adjustable as are the IP 100/200 series meters. Installation in the fitting ensures correct depth placement in the pipe. Fittings are available in PVC, brass, and stainless steel. Sensors are available in brass, 316 stainless steel, PVC, and polypropylene. In plastic pipe 3"-8", use an IP82 sensor, which is 1.00" longer than the IP81 to accommodate the larger fittings.

Features

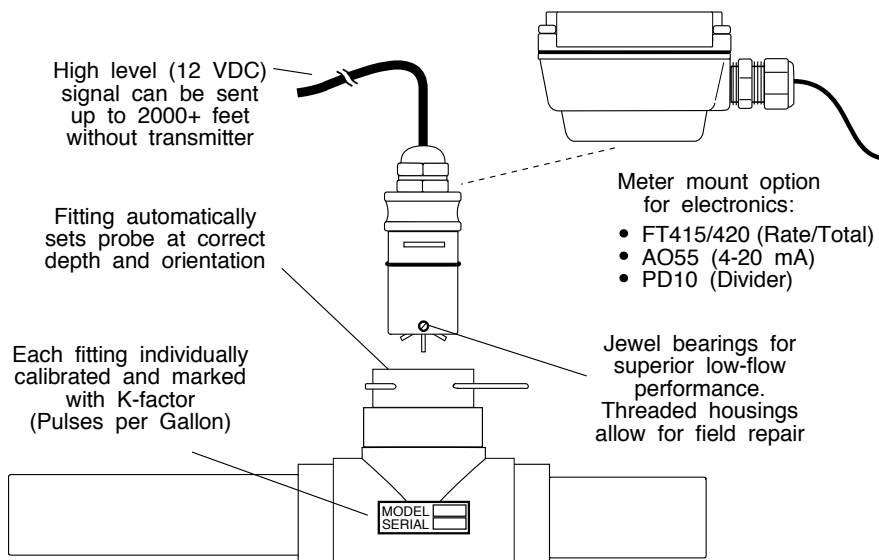

Specifications

Sensor	Hall Effect Sensor	12 VDC current sinking pulse
Materials	Sensor Body	PVC, Polypro, Brass, or 316 SS
	Rotor	Kynar
	Shaft	Nickel-bound tungsten carbide, ceramic optional
	Bearings	Ruby jewel
Maximum Pressure	PVC	175 PSI (12 bar) at 75° *
	Polypro	175 PSI (12 bar) at 75° *
	Brass	200 PSI (14 bar)
	316 SS	250 PSI (17 bar)
Maximum Temperature	PVC, Polypro	130° F (55° C)*
	Brass, SS	200° F (93° C)
Accuracy		1-1/2% FS
Flow Range (GPM)		
	1/2" 3/4" 1" 1-1/2" 2" 3" 4" 6" 8"	
Min	0.28 0.5 0.8 1.9 3.1 6.9 12 27 47	
Max	28 50 80 190 314 691 1200 2700 4700	
Cable		#22 AWG 3-con, 18'

* (see Pressure vs. Temperature chart)

Installation



These water meters are not recommended for installation downstream of the boiler feedwater pump where installation fault may expose the meter to boiler pressure and temperature. Maximum recommended temperature is 130°F (Plastic), 200°F (Metal).

Fitting Installation. IP80 Series meters require special fittings. The meter fitting must first be installed in the pipeline. Straight pipe of at least ten times the diameter upstream of the meter and five diameters downstream are strongly recommended. Inadequate straight pipe, especially downstream of an elbow, change in pipe diameter, or partially-opened valve, can result in significant inaccuracy. Typically this inaccuracy is in the form of the meter reading high. Some IP80 Series meter fittings are supplied with upstream straight pipe.

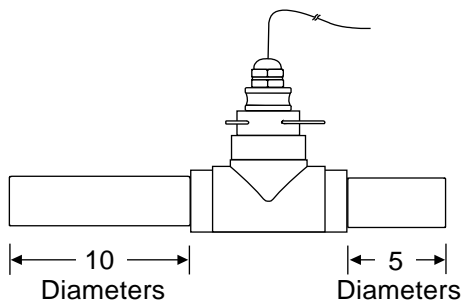

In the larger sizes, the length provided is less than ten diameters upstream and five downstream. It is not advisable to connect directly to the end of these fittings with a flow-disturbing device such as a valve or elbow. If possible, straight pipe should be added to these fittings.



Caution: Never remove the u-clip retainer when the pipe is under pressure. Always remove pressure from the pipe before attempting to remove the meter. Removal under pressure may result in damage or serious injury.

A PVC fitting is usually installed by solvent welding. The stainless steel and brass meter fittings have female pipe threads, requiring the appropriate male threaded fittings. Saddle fittings (size 3" and above) require a hole to be cut in the pipe. The recommended hole size is 1-3/4".

Meter Installation. After the meter fitting is installed in the pipeline, the meter can be installed in the fitting. Press the meter into the fitting as far as it will go. Then retain the meter in place by inserting the u-pin. This pin can be installed from either side. It is sometimes necessary to rotate the probe back and forth slightly to start the pin into the slots on the probe. Slide the pin in as far as it will go.

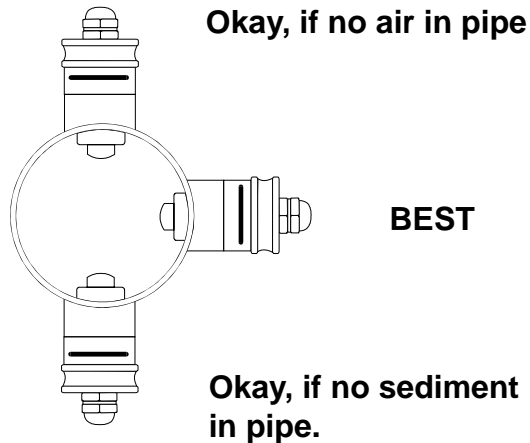

Meter Connection. See the "IP80 Series Connections" diagram for meter connections. Unless the meter is supplied pre-connected to a meter-mounted FT415/420 flow indicator, three leads must be connected. These three leads are color coded. The red wire is 6-24 VDC positive, the black is negative, and the white wire is the signal lead.

IP80 Series Connections

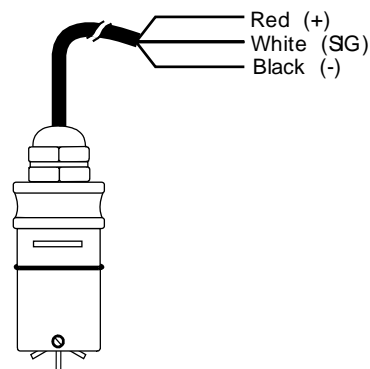

K-factor. If the IP80 Series meter is ordered with its fitting, the meter is factory calibrated in the fitting. A K-factor (meter factor) is indicated on the side of the fitting. This represents the actual number of pulses per gallon the meter produced during the factory flow test. This number can be entered into an FT415/420 or FT5210 flow indicator to make it read properly. If a pulse divider is being used, the K-factor is the starting point for calculating the divider number.

Maintenance and Repair

Rotor Replacement. Rotors are easily field-replaced. Shaft and rotor are a single unit, and are not replaced separately. If replacement is due only to normal shaft wear, bearing replacement is probably not necessary. If the rotor has been damaged by impact, the bearings should also be replaced. Rotor and bearings can be ordered as a kit, Part No.25901. Follow these steps:

1. Unscrew the threaded bearing housings to expose the shaft ends. If bearings are being replaced, back them completely out.
2. Remove the rotor. Put the new rotor in its place.
3. Thread in one bearing housing part way, then the other. Take care to start the end of the shaft into the bearing hole before tightening further.
4. Screw in bearing housings until they bottom. **Note: Do not use excessive force.**
5. Check for free spin. Blowing lightly on the rotor should result in it spinning rapidly and coasting to a smooth stop.



Sensor Replacement. It is very unusual for a sensor to require replacement in normal use. The primary cause of sensor failure is overvoltage (inadvertent connection of line voltage, for example) or incorrect polarity on hookup. The sensor is replaced by removing the the strain relief, then threading out the sensor retainer plug. Remove the entire sensor capsule by pulling on the cable. The new sensor capsule can then be installed. It is important to orient the sensor capsule properly. Replace the retainer plug, and then replace and tighten the strain relief.

Troubleshooting Guide			
Problem	Probable Cause	To Check	To Repair
No signal after installation	Insufficient flow	See Min. GPM for size	Contact SeaMetrics
	Bad connections to control electronics	Check connections at control. Check polarity: red (+), black (-), white (signal)	Re-connect if necessary
	Incompatible control	Does control: 1) provide 6-24VDC power; 2) accept current sinking inputs	Contact SeaMetrics
	Damaged or missing rotor	Remove meter and check visually for free spinning	Obtain new rotor and replace
Inaccurate metering	Not enough straight pipe between meter and flow disturbance	See recommendations, measure	Move meter away from flow disturbance or field calibrate

Fittings Compatibility Chart		
Material	IP81	IP82
Bronze	1"- 4" Tee	3"- 8" Braze fitting
PVC	1/2"- 2" Tee	3"- 8" Saddle
Polypro	N/A	3"- 8" Tee
Stainless steel	1/2"- 2" Tee	3"- 8" Weld fitting
Carbon steel	1/2"- 2" Tee	3"- 8" Weld fitting

IP80 Series Parts Listing		
1	Upper housing	26181
2	Gasket	26211
3	Lower housing	29930
4	Housing screw	26229
5	Plug, steel	26073
6	Plug, plastic	26079
7	Strain Relief	7655
8	Sensor Retainer	25321
9	Sensor	26310
10	Body	*
11	Bearing assembly (2)	25901
12	O-ring	25081
13	Rotor	11130
14	Fitting	*

* Consult distributor or price pages

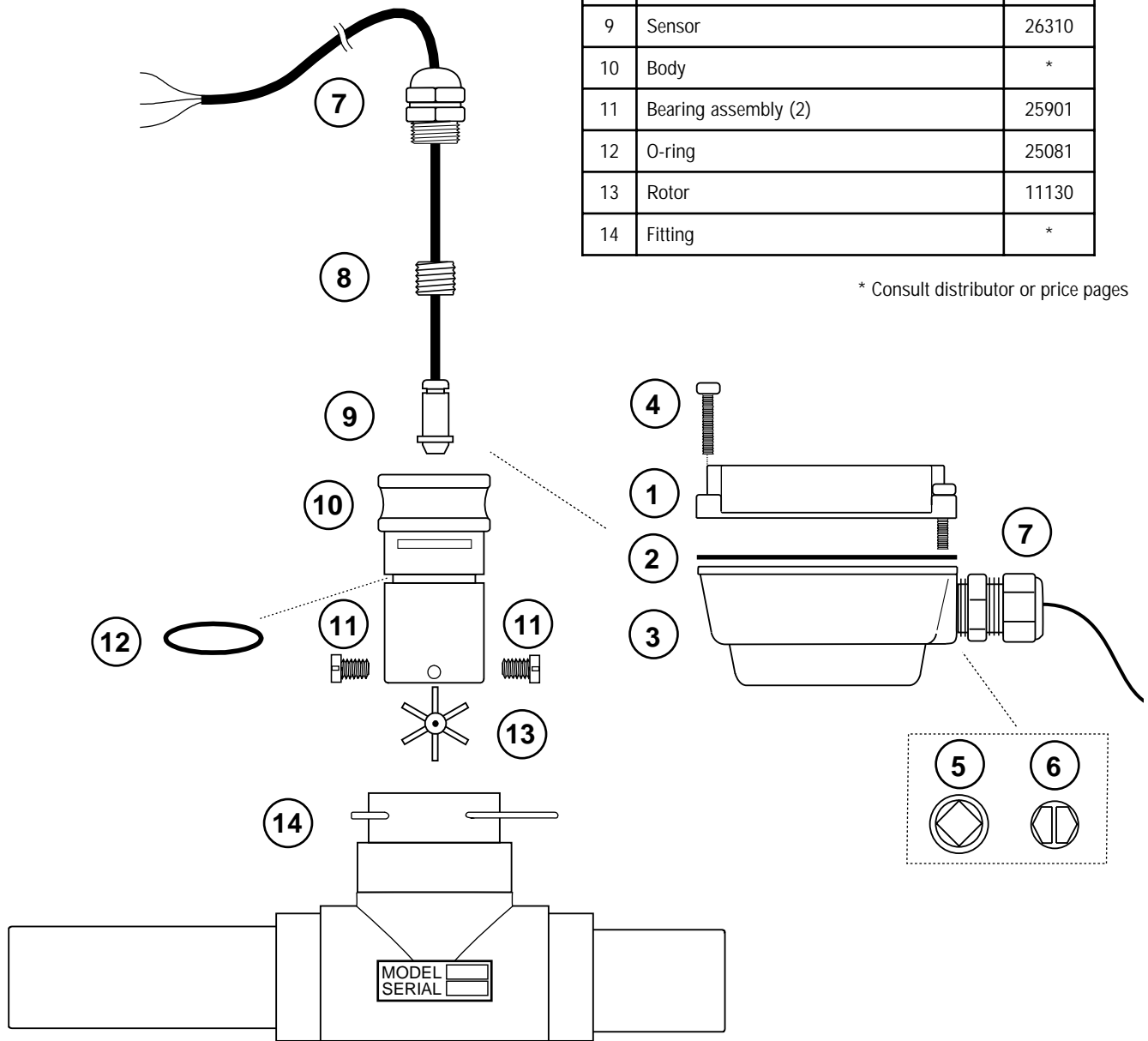

SeaMetrics

20419 80th Ave. So., Kent, WA 98032 USA
 Phone: 253-872-0284 Fax: 253-872-0285
www.seametrics.com 1-800-975-8153