

# EX100/200-Series

## INSERTION MAGNETIC FLOW METER INSTRUCTIONS

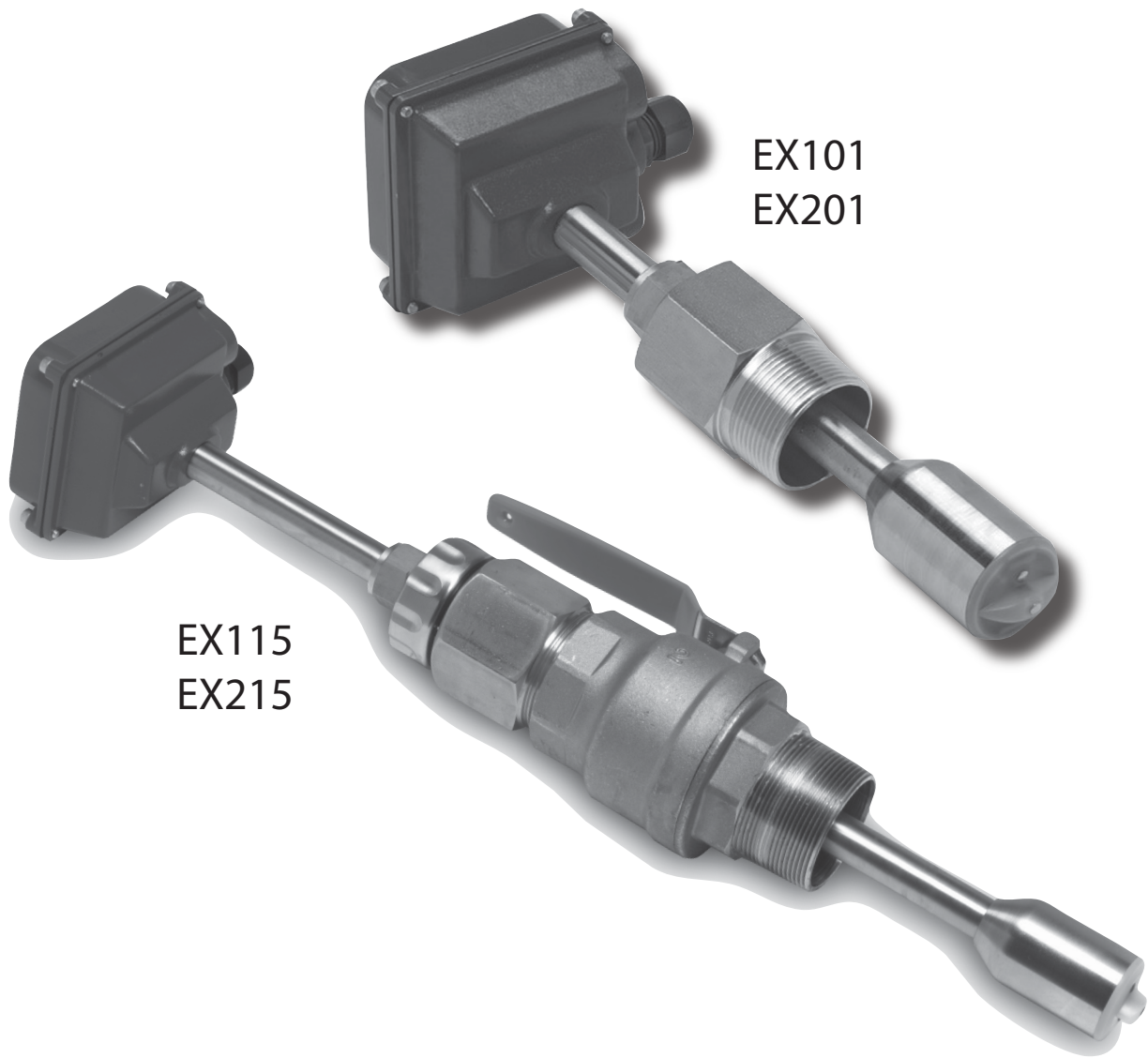

EX101  
EX201

EX115  
EX215

EX100/200-SERIES INSERTION MAGNETIC FLOW METER INSTRUCTIONS



The Leader in Flow Meter Value

## TABLE OF CONTENTS

---

### General Information

General Information, Features, Specifications..... **Page 1**

### Installation

Piping, Distorted Flows, Immersion, Positioning the Meter..... **Page 2**

Fitting Installation, Meter Installation ..... **Page 3**

Proper Depth Setting ..... **Page 4**

Dimension "C", Pipe Wall Thickness ..... **Page 5**

Straight Pipe Recommendations ..... **Page 6**

Full Pipe Recommendations ..... **Page 7**

### Electrical Connections

General Electrical Guidelines, Power, Forward (and Reverse) Flow Output,  
Grounding Guidelines, Grounding Diagram..... **Page 8**

### Connections Diagrams

Counter or PLC, A055 4-20 mA Output, FT520 Controller ..... **Page 9**

FT420 Display and Proportional Feed, FT420 & 4-20 mA Output, Dual FT420 Displays..... **Page 10**

DL75 Data Logger, FT420/DL75 ..... **Page 11**

### Operation & Maintenance

Zero Adjustment, Minimum Flow, Presence of Flow Indication, Filtering,  
Electrode Coating, Calibration ("K-Factor"), Flow Rates in Gallons Per Minute ..... **Page 12**

### Troubleshooting

Problems, Probable Causes and Things to Try ..... **Page 13**

## TABLES, DIAGRAMS & CHARTS

---

Features..... **Page 1**

Distorted Flows, Positioning the Meter..... **Page 2**

Meter Installation, Sensor Removal ..... **Page 3**

Proper Depth Setting ..... **Page 4**

Dimension "C", Pipe Wall Thickness ..... **Page 5**

Straight Pipe Recommendations..... **Page 6**

Full Pipe Recommendations ..... **Page 7**

Grounding Diagram..... **Page 8**

Connection Diagrams: Counter or PLC, A055 4-20 mA Output, FT520 Controller ..... **Page 9**

Connection Diagrams: FT420 Display and Proportional Feed, FT420 & 4-20 mA Output,  
Dual FT420 Displays ..... **Page 10**

Connection Diagrams: DL75 Data Logger, FT420/DL75 ..... **Page 11**

Zero Adjustment, Flow Rates in Gallons Per Minute ..... **Page 12**

Troubleshooting Problems, Probable Causes and Things to Try ..... **Page 13**

## GENERAL INFORMATION

The complete lack of moving parts of this insertion flow sensor is the source of its reliability. There is no rotor to stop turning in dirty water and there are no bearings to wear out. Brass and stainless steel models withstand a variety of temperature, pressure, and chemical conditions. Reverse flow output and immersibility are optional.

A rapidly reversing magnetic field is produced in the lower housing. As the fluid moves through this field, a voltage is generated that is measured and translated into a frequency signal proportional to flow rate. This square wave signal can be sent directly to a PLC or other control or can be converted using any of the SeaMetrics family of indicators and converters.

A modular system of electronics can be attached directly to the flow sensor or remotely mounted. The SeaMetrics FT420 provides indication of rate and total, plus 4-20 mA output. The AO55 provides blind 4-20 mA output, and the DL75 is a battery-powered data logger. The EX100/200-Series is also compatible with the FT520 batching flow processor.

The adapter fitting of the EX sensor is standard male NPT, and can be directly threaded into ordinary saddles or threaded weld fittings. The EX115 and 215 include an isolation valve, allowing hot-tap installation, or installation and removal under pressure. A bronze ball valve is standard, with a 316 stainless steel valve optional.

### FEATURES

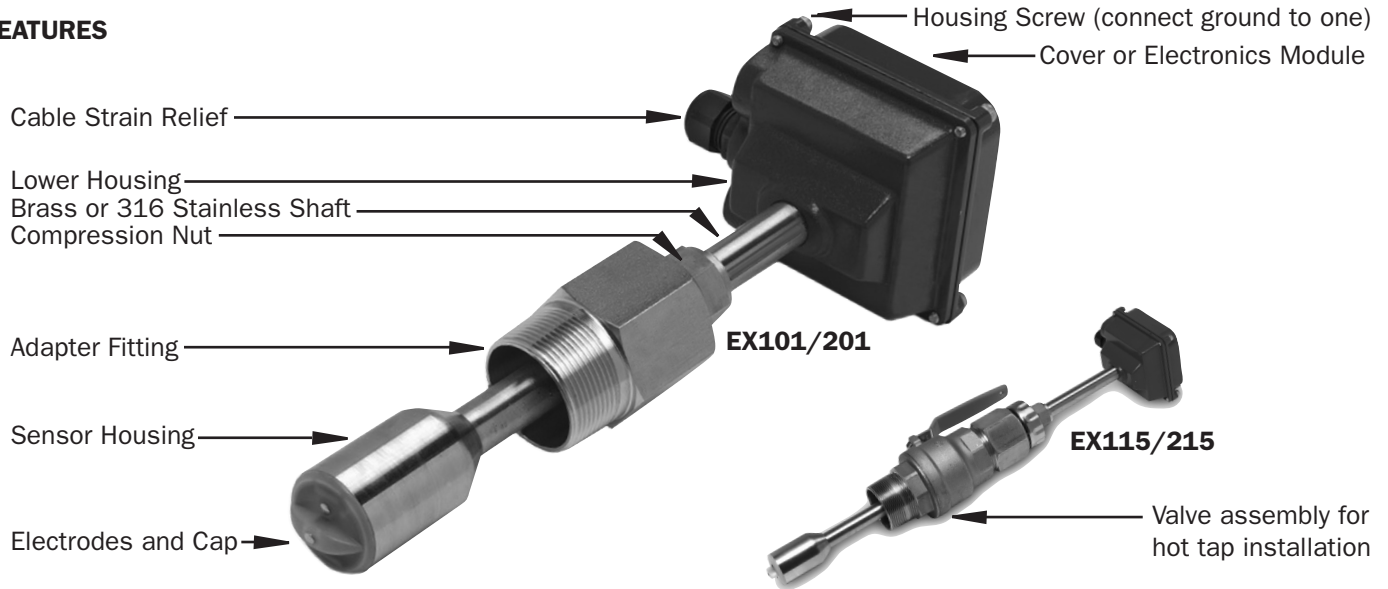

### SPECIFICATIONS

<b>Power</b>	<b>Full Power</b>	12-24 Vdc, 250 mA	
	<b>Low Power</b>	12-24 Vdc, 40 mA	
<b>Flow Range</b>	0.28 - 20 ft/sec (0.08 - 6.09 m/sec)		
<b>Fitting Size</b>	<b>EX101/201</b>		<b>EX115/215</b>
	1-1/2" Male NPT		2" Male NPT
<b>Temperature</b>	<b>Ambient</b>	0° - 180° F (-17° - 82° C)	
	<b>Fluid</b>	32° - 200° F (0° - 93° C)	
<b>Pressure</b>	200 psi (13.8 bar)		
<b>Minimum Conductivity</b>	20 microSiemens/cm		
<b>Materials</b>	<b>Shaft/Fitting</b>	316 SS or Brass	
	<b>Electrodes</b>	Hastelloy	
	<b>Electrode Cap</b>	PVDF	
	<b>Housing</b>	Cast powder-coated aluminum	
	<b>Valve Assembly (115/215 Only)</b>	Bronze (stainless optional) with bronze ball valve	
	<b>O-Ring (115/215 Only)</b>	EPDM	
<b>Calibration Accuracy</b>	+/- 1% of full scale		
<b>Output</b>	Square wave pulse, opto isolated, 550 Hz @ 20 ft/sec 6 mA max, 30 Vdc forward flow standard; reverse flow optional		
<b>Empty Pipe Detection</b>	Software, defaults to zero flow		

## INSTALLATION

**Piping.** For best results, the EX sensor should be installed with at least ten diameters of straight pipe upstream and five downstream. Certain extreme situations such as partially-opened valves are particularly difficult and may require more straight diameters upstream (see page 6 for straight pipe recommendations).

### DISTORTED FLOWS

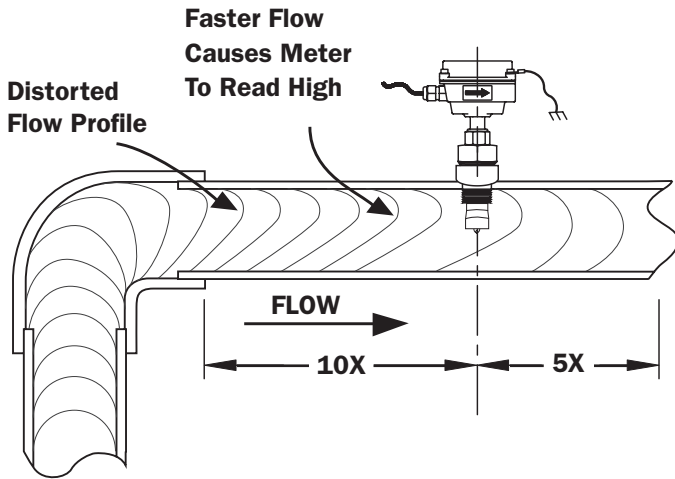

**Immersion.** The 100/200-Series standard sensors are not designed for continuous underwater operation. If this is a possibility, as in a flooded vault, a unit modified for immersion should be specified (Option -40).

**Chemical Injection or Fertigation.** When any magmeter, by any manufacturer, is used in a chemical injection application (including fertigation), the chemical line must be placed downstream of the magmeter OR far enough upstream for complete mixing to occur before the fluid reaches the meter. When unmixed chemical or fertilizer alternates with water passing through the meter, the rapid changes in conductivity may cause sudden spikes and drops in the meter's reading, resulting in inaccurate measurement. The magmeter will restabilize, however, with a steady flow of fluid of uniform conductivity.



**Caution:** In chemical injection or fertigation applications, install chemical line downstream of magmeter, or far enough upstream to allow complete mixing of fluids before the meter.

### POSITIONING THE METER

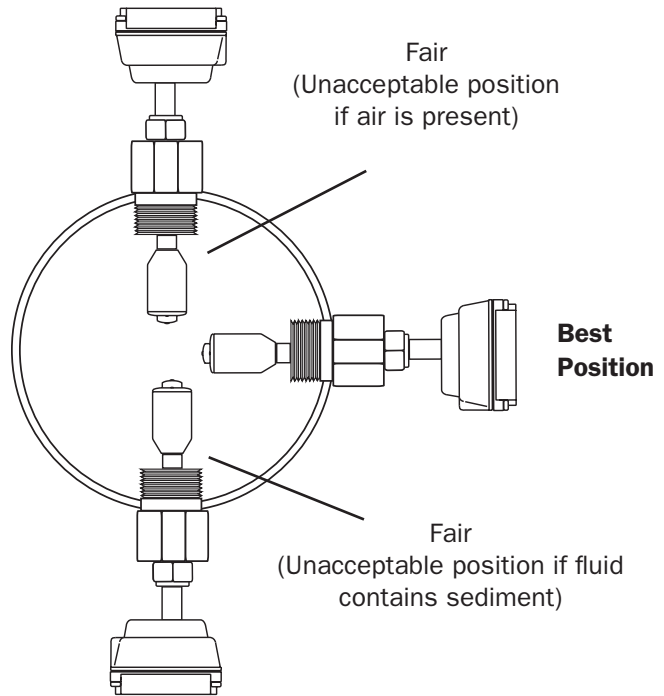

Horizontal is the preferred installation orientation, since it improves low-flow performance and avoids problems with trapped air and sediment. Bottom, top, and vertical pipe installations are all acceptable if required by the piping layout.



**Caution:** These flow sensors are not recommended for installation downstream of a boiler feedwater pump where installation fault may expose the flow sensor to boiler pressure and temperature. Maximum recommended temperature is 200°F.

## INSTALLATION

### EX101/201 INSTALLATION

**Fitting Installation.** EX101/201 sensors come with a 1-1/2" male NPT pipe thread adapter fitting. Any fitting that provides the matching NPT female thread may be used. Installation procedure compensates for fitting height differences. Cut a minimum 1-3/4" hole in the pipe. If possible, measure the wall thickness and write it down for use in depth setting. Then install the threaded fitting (saddle, weldolet, etc.) on the pipe.

**Meter Installation.** Loosen the compression nut so that the adapter slides freely. Pull the meter fully upward and finger-tighten the compression nut. Using a thread sealant, install the adapter in the pipe fitting. Do not overtighten. Now loosen the compression nut, lower the meter to the appropriate depth setting (see diagram and instructions that follow). Be sure flow is in the direction of the arrow on the housing. Tighten compression nut fully.

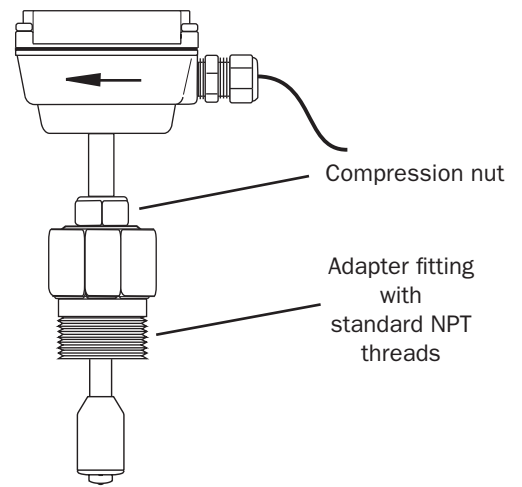

### EX115/215 INSTALLATION

'Hot tap' EX meters are designed to be installed and serviced without depressurizing the pipe.

**Fitting Installation.** The EX115 and 215 sensors have a 2" NPT thread for compatibility with the 2" isolation valve. Any fitting that provides matching NPT female thread may be used. The installation procedure compensates for differences in fitting height.

If initial installation is performed on an unpressurized pipe, cut a minimum 1-3/4" hole in the pipe. If possible, measure the wall thickness and write it down for use in depth setting. Then install the threaded fitting (saddle, weldolet, etc.) on the pipe.

If it is necessary to do the initial installation under pressure, any standard hot tap drilling machine with 2" NPT adapter, such as a Transmate or a Mueller, can be used. Ordinarily, it is not necessary to use an installation tool, since the small-diameter tube can be controlled by hand at all but the highest pressures.

**Meter Installation.** Remove the sensor unit from the valve assembly. Using a thread sealant, install the valve assembly on the pipe fitting. If the initial installation is a pressure ("hot") tap, remove the 1-1/2" x 2" adapter bushing at the back of the valve. Thread the tapping machine on, open the valve, and tap using a minimum of 1-3/4" or maximum 1-7/8" cutter. After retracting the machine and closing the valve, reinstall the flow sensor. When the sensor is secure, open the valve and adjust depth setting (see diagram and instructions that follow). Be sure flow is in the direction of the arrow on the housing. Tighten locking collar and compression nut fully.

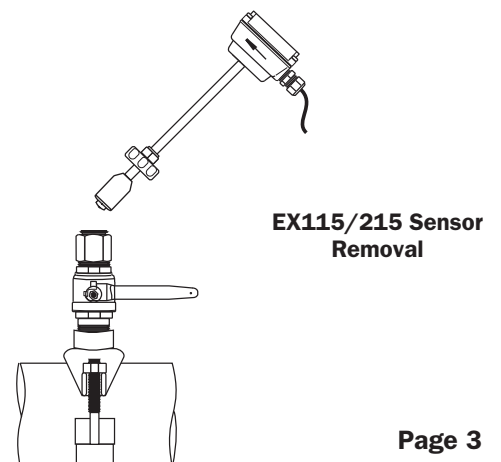
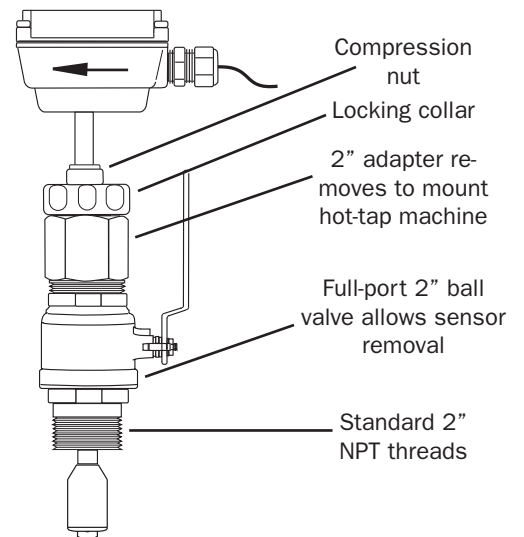

## INSTALLATION

### PROPER DEPTH SETTING

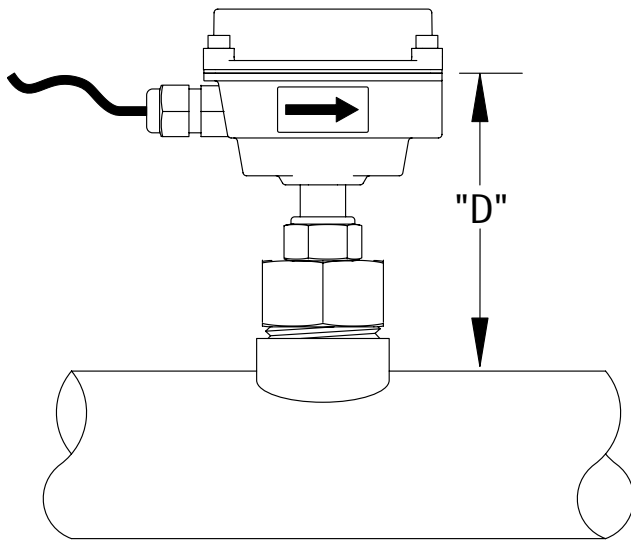

**Caution!** Never attempt to remove a flow sensor when there is pressure in the pipe unless it is specifically designed for hot tap installation and removal. Loosen the compression nut slowly to release any trapped pressure. If fluid sprays out when removing the sensor, stop turning and depressurize the pipe. Failure to do so could result in the sensor being thrown from the pipe, resulting in damage or serious injury.

**Depth Setting.** It is important for accuracy that the sensor be inserted to the correct depth into the pipe.

1. In Table 1, find Dimension C for your sensor model and pipe size. Subtract wall thickness of your pipe (Table 2) to find Dimension D.

**NOTE: When you calculate your K-factor as described on page 12, Dimension D will be given also.**

2. Measuring from the outside of the pipe to the joint in the housing, as shown in the diagram, adjust the sensor to Dimension D and hand-tighten compression nut.
3. Align the conduit housing with the centerline of the pipe, as shown. Be sure the arrow on the housing points in the direction of flow.

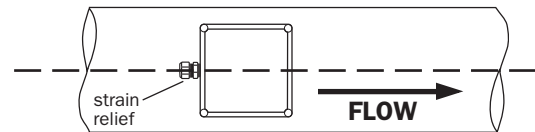

4. Check Dimension D one more time.
5. Tighten the compression nut fully.

## INSTALLATION

**TABLE 1: DIMENSION “C”**

	NOMINAL PIPE SIZE												
	3”	4”	6”	8”	10”	12”	14”	16”	18”	20”	24”	30”	36”
<b>EX101</b>	10.04	9.93	9.69	9.46	9.22	8.99	8.75	8.52	8.28	8.05	7.58	6.87	6.17
<b>EX201</b>	15.04	14.93	14.69	14.46	14.22	13.99	13.75	13.52	13.28	13.05	12.58	11.87	11.17
<b>EX115</b>	17.04	16.93	16.69	16.46	16.22	15.99	15.75	15.52	15.28	15.05	14.58	13.87	13.17
<b>EX215</b>	21.04	20.93	20.69	20.46	20.22	19.99	19.75	19.52	19.28	19.05	18.58	17.87	17.17

**TABLE 2: PIPE WALL THICKNESS**

	NOMINAL PIPE SIZE												
	3”	4”	6”	8”	10”	12”	14”	16”	18”	20”	24”	30”	36”
<b>PVC/Steel Sch. 40</b>	0.216	0.237	0.280	0.322	0.365	0.406	0.438	0.500	0.562	0.593	0.687		
<b>PVC/Steel Sch. 80</b>	0.300	0.337	0.432	0.500	0.593	0.687	0.750	0.843	0.937	1.031	1.218		
<b>Stainless Steel (10S)</b>	0.120	0.120	0.134	0.148	0.165	0.180	0.188	0.188	0.188	0.218	0.250	0.312	0.312
<b>Stainless Steel (40S)</b>	0.216	0.237	0.280	0.322	0.365	0.375	0.375	0.375	0.375	0.375	0.375	0.375	0.375
<b>Copper Tubing (Type L)</b>	0.090	0.110	0.140	0.200	0.250	0.280							
<b>Copper Tubing (Type K)</b>	0.109	0.134	0.192	0.271	0.338	0.405							
<b>Brass Pipe</b>	0.219	0.250	0.250	0.312	0.365	0.375							
<b>Duct. Iron (Class 52)</b>	0.280	0.290	0.310	0.330	0.350	0.370	0.390	0.400	0.410	0.420	0.440	0.470	0.530

# INSTALLATION

## STRAIGHT PIPE RECOMMENDATIONS

(X = diameter)

Reduced Pipe

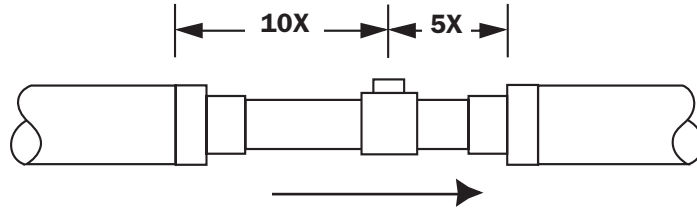

Two Elbows In Plane

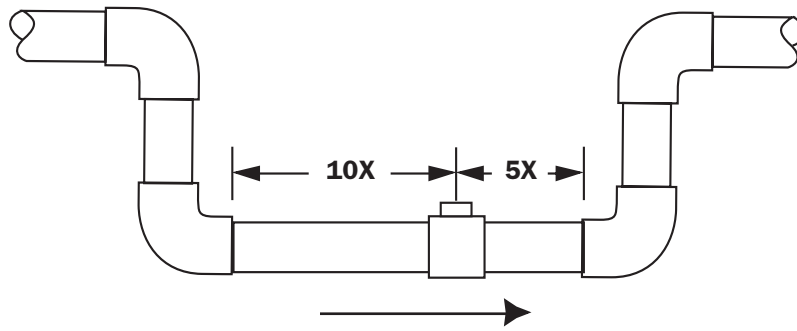

Two Elbows, Out Of Plane

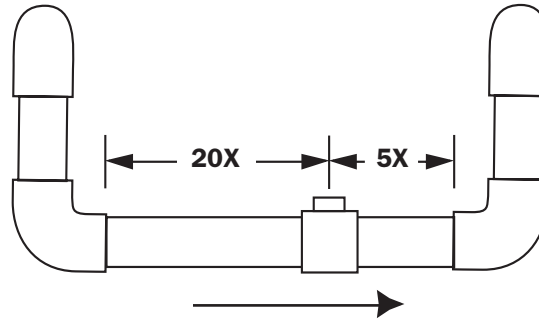

Expanded Pipe

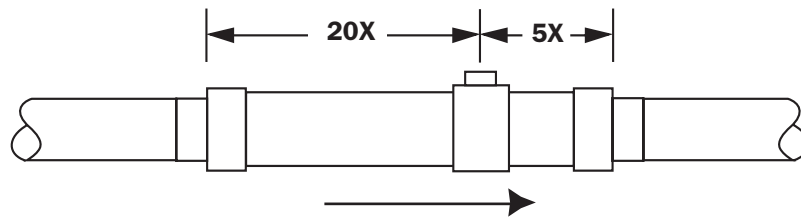

Spiral Flow

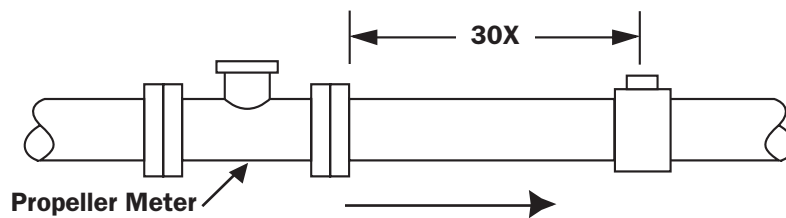

Swirling Flow

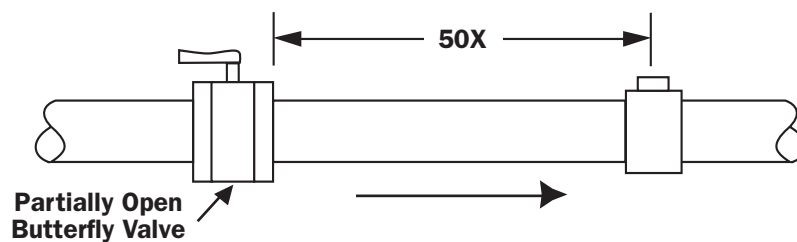



# INSTALLATION

## FULL PIPE RECOMMENDATIONS

### Possible Problem

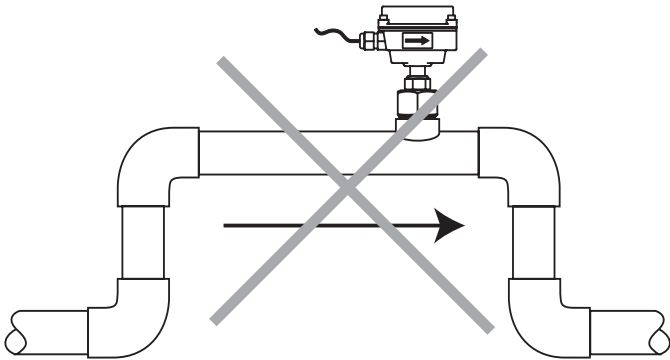

Allows air pockets to form at sensor

### Better Installation

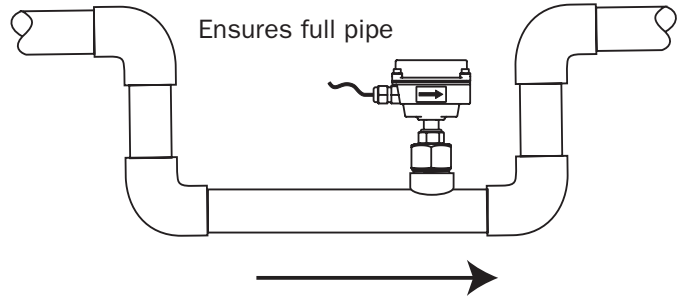

### Possible Problem

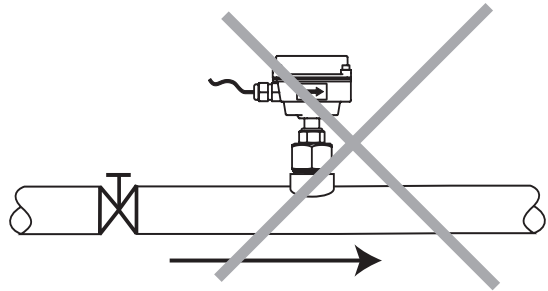

Post-valve cavitation can create air pocket

### Better Installation

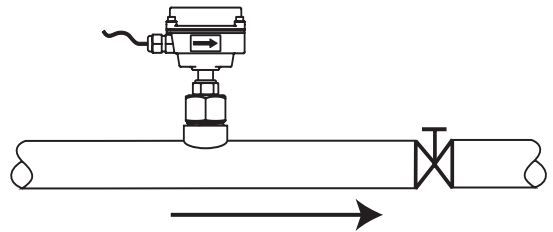

Keeps pipe full at sensor

### Possible Problem

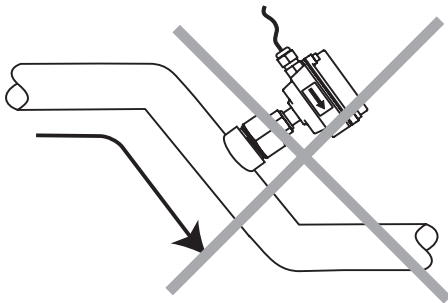

Air can be trapped

### Better Installation

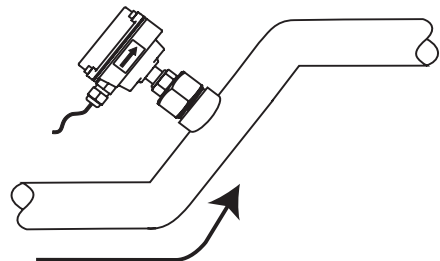

Allows air to bleed off



**Caution:** These flow sensors are not recommended for installation downstream of a boiler feedwater pump where installation fault may expose the flow sensor to boiler pressure and temperature. Maximum recommended temperature is 200°F.

## ELECTRICAL CONNECTIONS

---

### General Electrical Guidelines:

- Whenever possible avoid running control cables in the same conduit with AC power.
- Using shielded cable, be sure that one end is grounded.
- Avoid routing flow sensor cables in close proximity to a variable frequency drive.
- Recommended power and output wiring is shielded 18-22 AWG control cable.
- Recommended voltage is 12-24 Vdc. Note that unregulated power supplies can vary from nameplate voltage by a considerable amount. When in doubt, use a regulated power supply.

See the Connections diagrams on the following pages for the appropriate terminals.

**Power:** A 12 - 24 Vdc power supply capable of at least 250 mA current output is needed.

**Forward (and Reverse) Flow Output:** This open-collector isolated output does not supply power. It functions like a polarity-sensitive switch closure. This pulse is generated in the forward flow direction on the standard unit. (Reverse flow output is available as an option).

Note: This output is limited to 6 mA at 30 Vdc maximum.

### Grounding Guidelines:

For best results, use a good quality earth ground, such as metallic water piping, or a stake driven into the ground, to ensure a good connection to earth ground and good noise suppression.

If the flow sensor is installed in metallic piping, for optimum connection clamp wire to the piping a short distance to one side of the flow sensor using a hose type clamp. Connect the wire to the earth ground and to one of the housing screws. (For non-metallic piping, this step is not needed.)

EX meters are usually unaffected by moderate levels of electrical noise. In some applications performance may be improved by taking the following steps:

- Use shielded twisted pair cable (Belden 8723 or equivalent above ground or Alpha 35482 or equivalent burial).
- Clamp a ferrite bead (Steward 28A2029-OAO or equivalent) on meter signal/power wire within 3/4" of the meter strain relief (tape or tie wrap in place if necessary). See diagram below.
- **IMPORTANT** - Connect the cable shield ground wire to ground, **ONLY** at power supply end of cable.

### GROUNDING DIAGRAM

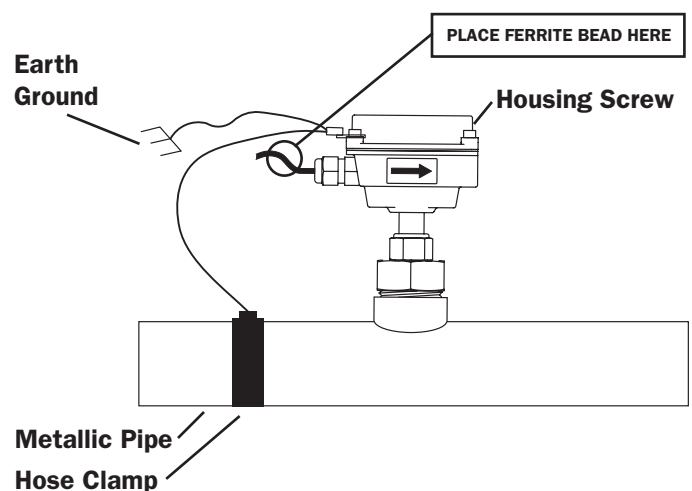

# CONNECTIONS DIAGRAMS

## COUNTER OR PLC

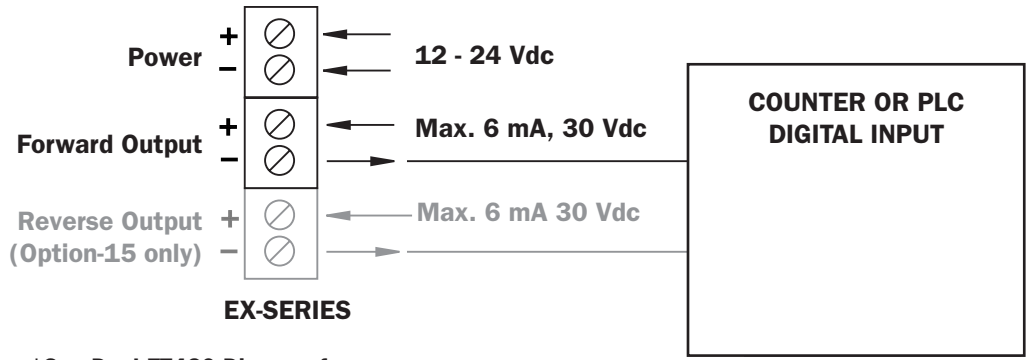

\*See Dual FT420 Diagram for an example of bidirectional connections.

## A055 4-20 mA OUTPUT

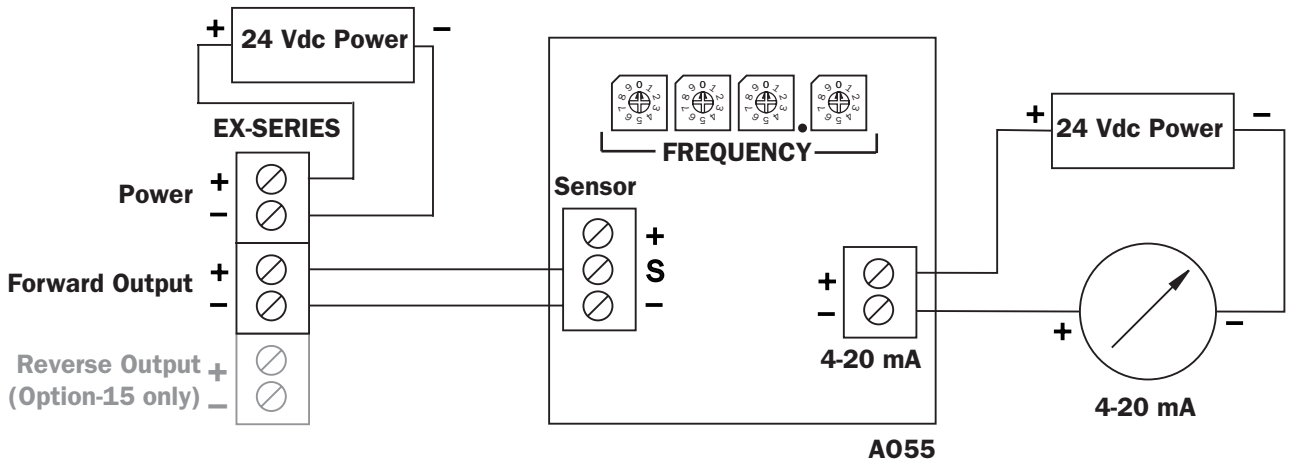

\*See Dual FT420 Diagram for an example of bidirectional connections.

## FT520 CONTROLLER

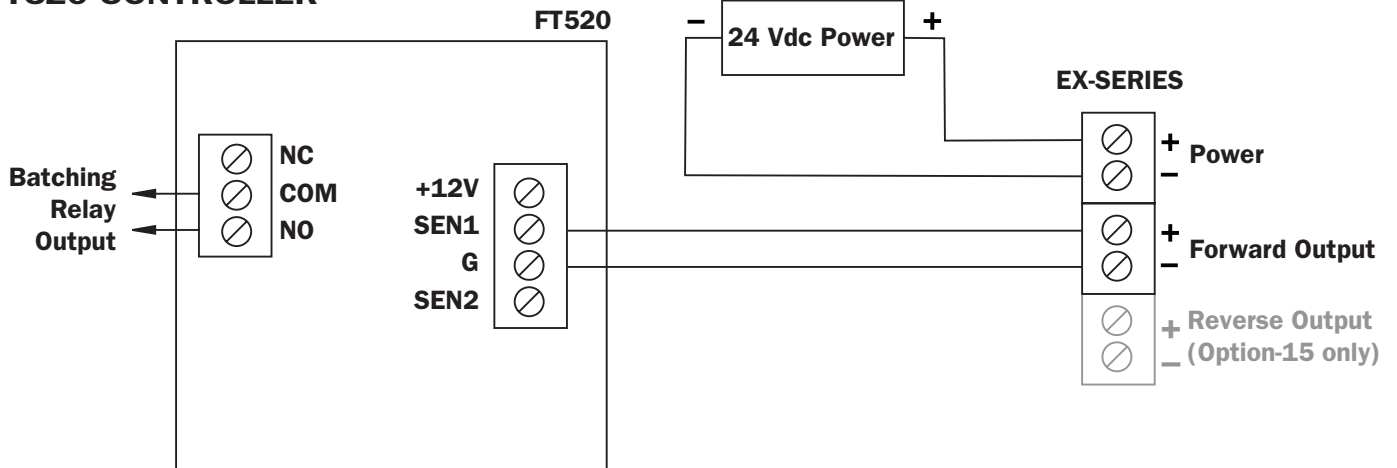

\*See Dual FT420 Diagram for an example of bidirectional connections.

# CONNECTIONS DIAGRAMS

## FT420 DISPLAY AND PROPORTIONAL FEED

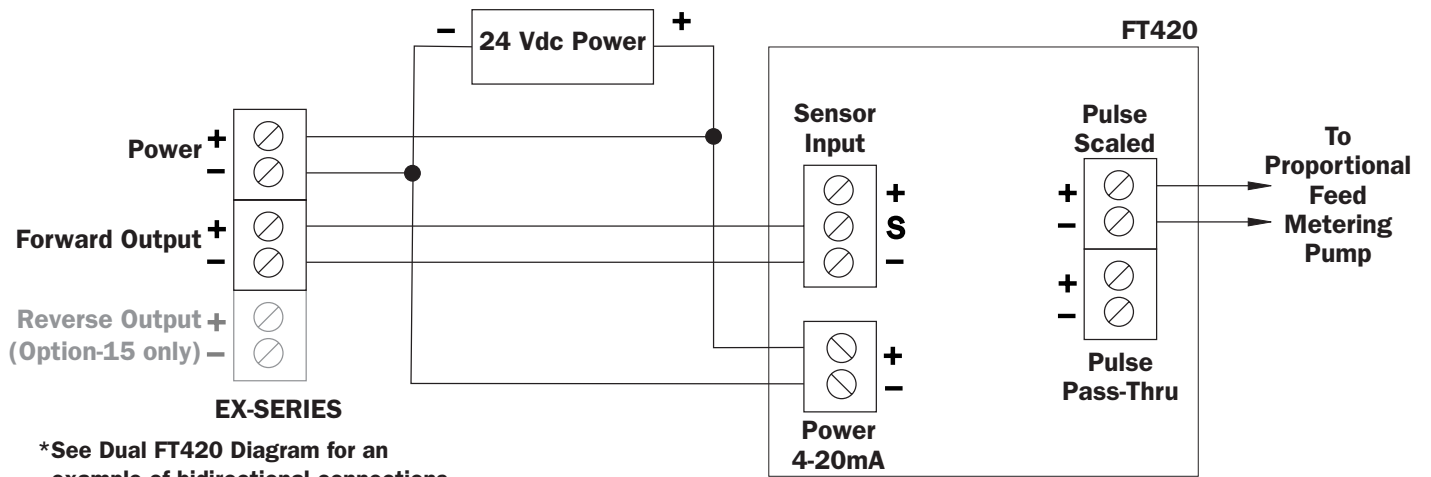

## FT420 DISPLAY AND 4-20 mA OUTPUT

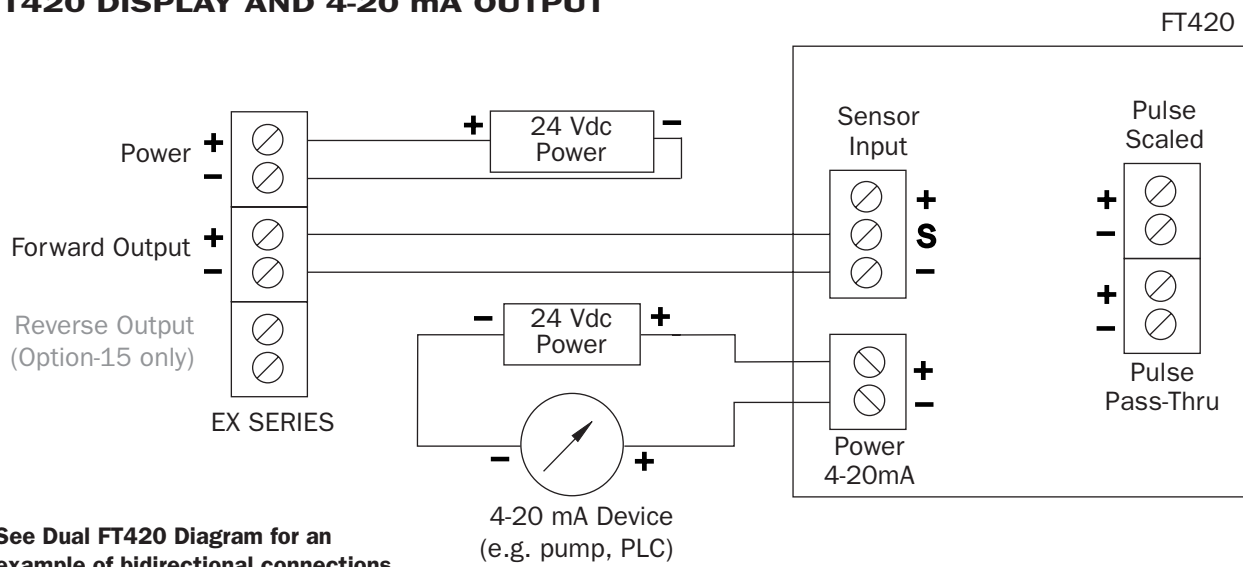

## DUAL FT420 DISPLAYS (Example of Bidirectional Connection)

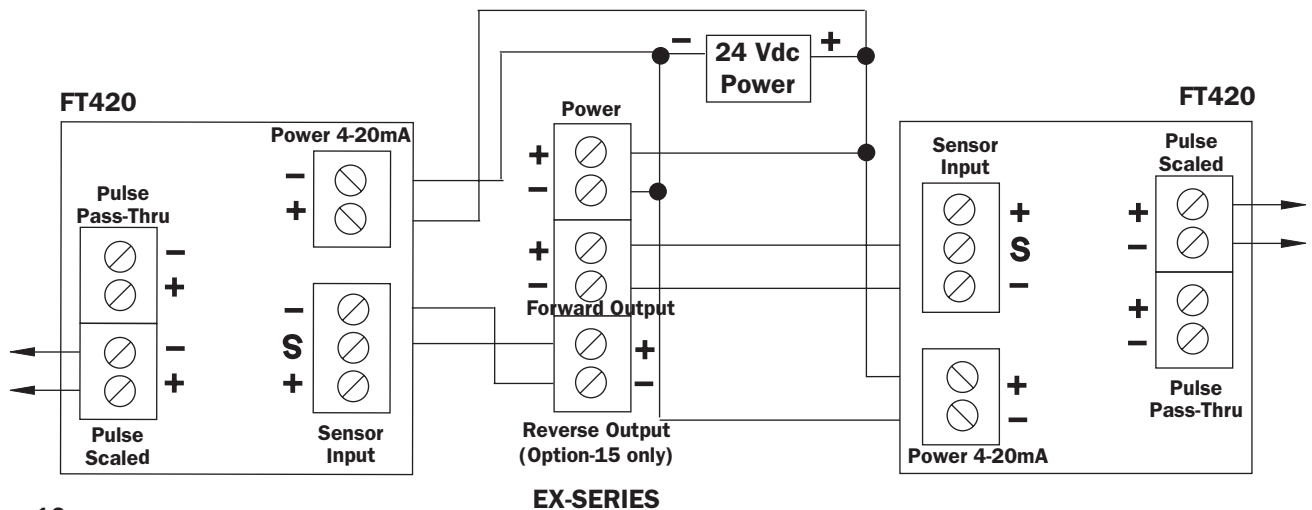

# CONNECTIONS DIAGRAMS

## DL75 DATA LOGGER

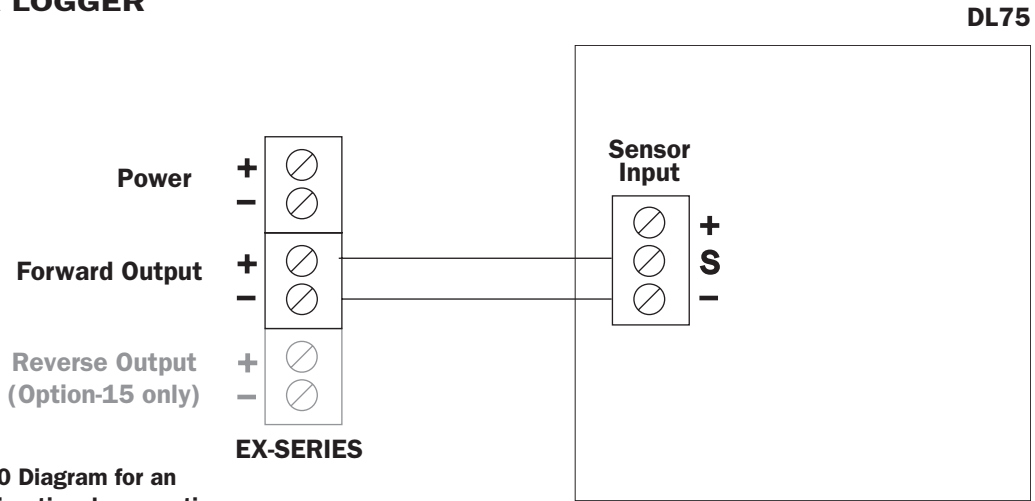

\*See Dual FT420 Diagram for an example of bidirectional connections.

## FT420/DL75

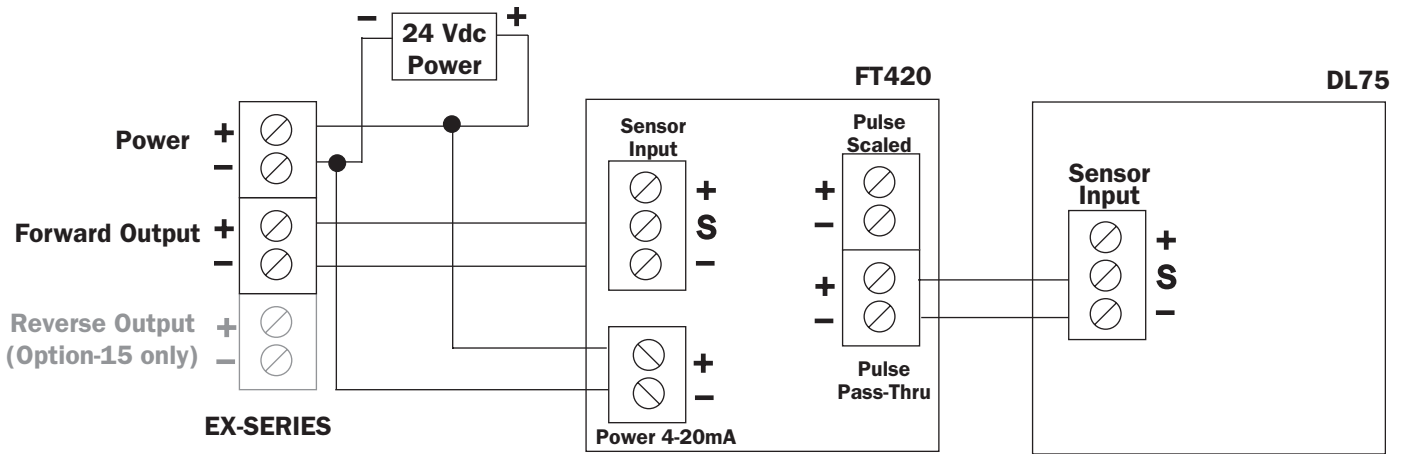

\*See Dual FT420 Diagram for an example of bidirectional connections.

## OPERATION & MAINTENANCE

**Zero Adjustment.** When the EX100/200-Series meter is powered up and there is no flow, there should be no output pulses (or, if connected to the FT420, flow rate should read “0”). If there are pulses, it may be necessary to adjust the flow meter under no-flow conditions after it has been installed. This should only be done if the indicated flow is low, near the lower cutoff.

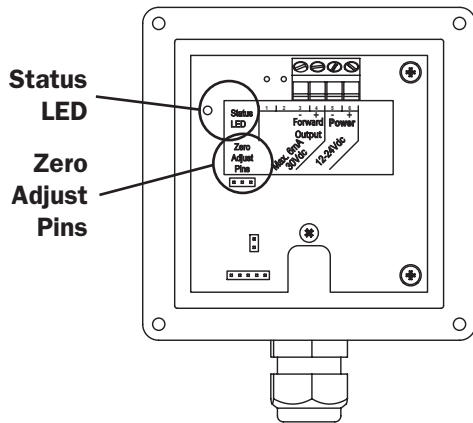

To perform the adjustment, after determining that there is a full pipe with no flow, short between the two pins marked “Zero Adjust”. A red LED light will come on for approximately 50 seconds and then go out. The zero adjustment is completed.

**Minimum Flow.** As with any other flow sensor, there is a rate below which the EX100-Series sensor cannot read. Check the table below for the minimum flow rate detectable by the sensor (at 0.2 ft/sec) for a given pipe size.

**Presence of Flow Indication.** To assist in troubleshooting, the “Status LED” has two blinking modes in normal operation. When there is no flow detectable by the meter (below minimum threshold) the LED blinks every 8.0 seconds. When there is detectable flow, the same indicator blinks every 3.0 seconds.

**Filtering.** The software of the EX100/200-Series filters out electrical noise and averages sudden variations in the flow to smooth the output. It takes a matter of seconds for the flow sensor to get up to full output when it is powered up or when flow begins.

**Electrode Coating.** Grease or other adhering, non-conductive materials can stop flow detection if the electrodes become heavily coated. To clean the electrodes, remove the sensor from the pipe and gently scrub the electrodes (three silver bumps) on the reading face of the flow sensor. A mild soap (dishwashing liquid for example) can be used to aid the cleaning process.

**Calibration (“K-Factor”).** In order to properly process pulses from the flow sensor, a number must be entered into the control to which the sensor is connected. This number, called the K-factor, is the number of pulses the sensor puts out per unit of fluid passing through the pipe. It is normally provided for SeaMetrics sensors in pulses per gallon, and can be ascertained by using the “K-Factor Calculator” on the SeaMetrics website. These numbers are based on extensive testing, which has shown close agreement among different EX sensors in the same installation. Typically, most K-factor error can be attributed to installation variables, such as depth setting and fitting configuration.

### Using the K-Factor Calculator:

- 1) Go to the SeaMetrics webpage ([www.seametrics.com/seakalc.htm](http://www.seametrics.com/seakalc.htm))
- 2) Select your meter
- 3) Choose units
- 4) Input external pipe diameter (measure) and wall thickness (measure, or look-up in Table 2 on page 5 of this manual)
- 5) Press Calculate to determine your K-factor (**NOTE:** Dimension D is also calculated.)
- 6) Enter your K-factor into your controller

### FLOW RATES (IN GALLONS PER MINUTE)

Feet Per Second	NOMINAL PIPE SIZE												
	3"	4"	6"	8"	10"	12"	14"	16"	18"	20"	24"	30"	36"
Min 0.2	4.5	8	18	31	49	70	96	125	159	196	282	440	635
Max 20.0	440	783	1762	3133	4895	7050	9596	12533	15863	19584	28200	44064	63452

## TROUBLESHOOTING

Problem	Probable Cause	Try...
No pulse output	Unit not grounded Below minimum flow cutoff Flow reversed Output connections reversed Pipe not full Excessive electrical noise No power Power reversed Fluid conductivity <20 microSiemens/cm	Connect to earth ground Check the Presence of Flow LED (see p. 12) Note flow direction arrow, reverse direction to meter Change output connections Check plumbing Check for proper electrical wiring Check for power across power input terminals Reverse connections Select another flow meter
Output pulses incorrect	Missing or incorrect ground wire Incorrect depth setting Fluid conductivity <20 microSiemens/cm Empty pipe Not enough straight pipe Excessive electrical noise	Check for proper ground Check depth setting from Dimension "C" table (page 4) Select another flow meter Check for full pipe or install meter in the vertical position Check for air pockets or turbulence. Refer to installation, page 6 Check for proper electrical wiring
Jumpy reading	Rapidly changing conductivity (in chemical injection or fertigation applications)	Install chemical injection line downstream of magmeter (or far enough upstream to allow complete mixing of fluids before meter)



**SeaMetrics Incorporated • 19026 72nd Avenue South • Kent, Washington 98032 • USA  
(P) 253.872.0284 • (F) 253.872.0285 • 1.800.975.8153 • [www.seametrics.com](http://www.seametrics.com)**

LT-11756-H  
7/31/07