

MX1A and MX1B: Laser Displacement Detection Sensors

- Built-in math capabilities available (MX1B only)
- Digital display on amplifier; easy setting and monitoring (MX1B only)
- Miniature sensor head is compact for high-density installations
- Excellent linearity: $\pm 0.0008"$ (or $20 \mu\text{m}$) $\pm 0.5\%$ of displacement (MX1A-B; MX1B-B)
- High resolution sensing: $0.0004" / 10 \mu\text{m} \approx 0\text{mV}$ (MX1A-B; MX1B-B)
- Two sensing ranges: 1.18" to 1.97" (30 to 50mm) and 1.97" to 5.12" (50 to 130mm)
- MX1B can measure thickness or differences in surface levels when used in combination with another MX1A or MX1B
- The shape, size, color, and material of the object do not detract from accurate measurement (see Note 1 below)
- Delayed laser, remote interlock, power supply key switch, and laser LED are all included on the sensor head — these features ensure safe operation
- Mount the amplifier on a 1.378" (35mm) DIN rail



1. *Laser sensing of mirror-like surfaces is not recommended. For best results detecting reflective surfaces, tilt the sensor to reduce direct laser reflection. Sensing at a small angle (approximately $\pm 10^\circ$) does not significantly reduce the sensing accuracy or linearity of the resulting analog output.*
2. **Warning:** *Class IIIb laser. Do not allow the laser to shine directly into the eyes. Always consider eye safety when installing a laser sensor. Make sure the laser beam cannot inadvertently shine into the eyes of people passing by or working in the vicinity. See laser safety information on page M-20.*



General Specifications	Power Voltage	120V AC @ 50/60Hz
	Allowable Range	85% to 110% of the rated voltage
	Power Consumption	MX1A: 15VA, MX1B: 25VA
	Dielectric Strength	Between terminal (except A.OUT, CAL OUT/IN, AG, and FG terminals) and housing: 1,500V AC, 1 minute
	Insulation Resistance	Between terminal (except A.OUT, CAL OUT/IN, AG, and FG terminals) and housing: 100M Ω (minimum), with 500V DC megger
	Operating Temperature	0°C to +50°C (performance will be adversely affected if the sensor becomes coated with ice)
	Operating Humidity	45% to 85% RH (avoid condensation)
	Storage Temperature	-20°C to +70°C
	Vibration Resistance	Damage limits: 16.7Hz, 2G, 1 hour in each of 3 axes (when de-energized)
	Shock Resistance	Damage limits: 100m/s ² (approximately 10G), 3 shocks in each of 3 axes
	Extraneous Light Immunity	Incandescent light: 3,000 lux (maximum), defined as incident or unwanted light received by a sensor, unrelated to the presence or absence of intended object
	Material	Housing: diecast zinc; Filter and lens: acrylic; (sensor head only)
	Degree of Protection	IP65 (sensor head only) — IEC Pub 529, sensors rated IP65 are dust-tight, water-resistant, and perform best when not subjected to particle or water blasts
	Weight, Amplifier	MX1A: Approximately 2.0kg, MX1B: Approximately 2.5kg
	Weight, Sensor Head	Short cable (P/N ends in "S"): Approximately 500g Long cable (P/N ends in "L"): Approximately 800g
Dimensions, Amplifier (HxWxD)	MX1A: 4.21" x 5.12" x 4.41" (107 x 130 x 112mm) MX1B: 4.21" x 6.69" x 4.41" (107 x 170 x 112mm)	
Dimensions, Sensor Head (HxWxD)	1.73" x 0.73" x 1.79" (44 x 18.5 x 45.5mm)	

Part Numbers: MX1A and MX1B Sensors

Part Number	Sensing Range	Resolution	Features	Sensor Head Cable Length
MX1A – A 12 R6S MX1A – A 12 R6L	1.97" to 5.12" (50 to 130mm)	0.002" (50 µm)	Display and calculation not available	16' – 4-7/8" (5m) 32' – 9-3/4" (10m)
MX1B – A 12 R6S MX1B – A 12 R6L			Display and calculation standard	16' – 4-7/8" (5m) 32' – 9-3/4" (10m)
MX1A – B 12 R6S MX1A – B 12 R6L	1.18" to 1.97" (30 to 50mm)	0.0004" (10 µm)	Display and calculation not available	16' – 4-7/8" (5m) 32' – 9-3/4" (10m)
MX1B – B 12 R6S MX1B – B 12 R6L			Display and calculation standard	16' – 4-7/8" (5m) 32' – 9-3/4" (10m)

IMPORTANT: The sensor head and amplifier are calibrated in pairs — use units with the same serial number together to avoid damage to the laser diode. Using different serial numbers together or making alterations to the sensor amplifier head or cable will void the factory warranty.

	MX1A-A, MX1B-A	MX1A-B, MX1B-B	
Functional Specifications	Reference Sensing Distance	3.54" (90mm)	1.57" (40mm)
	Detectable Sensing Range	±1.57" (40mm)	±0.39" (10mm)
	Analog Offset	±1V (±0.16" or 4mm) zero adjustment range	±1V (±0.04" or 1mm) zero adjustment range
	Analog Response Speed	Selectable: High-speed (F) = 1ms, Normal speed (S) = 20ms	
	Analog Output, Measured	±10V DC, 10mA (maximum), measured analog output voltage is proportional to displacement as follows: 0.25V per mm (MX1A-A and MX1B-A), 1V per mm (MX1A-B and MX1B-B)	
	Resolution*	0.002" (50 µm) = 12.5 mV	0.0004" (10 µm) = 10mV
	Linearity	±0.004" (100 µm) ±0.5% of displacement	±0.0008" (20 µm) ±0.5% of displacement
	Analog Input, Calculated (MX1B only)	Voltage range: ±10V DC; Impedance: 100kΩ, measured analog output from an MX1A or MX1B is used as the calculated analog input for the MX1B only; the calculated output voltage is proportional to the calculated values for the thickness or difference in levels: 0.25V per mm (MX1A-A and MX1B-A), 1V per mm (MX1A-B and MX1B-B)	
	Analog Output, Calculated (MX1B only)	±10V DC, 10mA (maximum), measured analog output from an MX1A or MX1B is used as the calculated analog input for MX1B only; the calculated output voltage is proportional to the calculated values for the thickness or difference in levels: 6.35V per inch or 0.25V per mm (MX1A-A and MX1B-A), 25.32V per inch or 1V per mm (MX1A-B and MX1B-B)	
	Digital Output	Transistor 30V DC, 0.1A/point (maximum), upper LED is lit when measured value > preset, lower LED is lit when < preset	
	Digital Output Setting	Separate settings for upper and lower limits (infinite turn)	
	Digital Output Response	Rise and fall: 500 µsec (maximum)	
	Out LED	On: digital output turns on	
	Upper and Lower LEDs	Upper LED on: Upper limit output turns on	Lower LED on: Lower limit output turns on
	Enable Input (Synchronous)	Controls inspection output with synchronous signal (one coupler)	
	Enable LED	On: For synchronous signal input	
	Alarm Input	Using 2 units together: Main unit (MX1B only) takes the alarm output from the sub unit (MX1A or MX1B)	
	Alarm Output	Transistor 30V DC, 0.1A / pt. (maximum), alarm output is lit when alarm condition exists, as displayed by the alarm LEDs	
Alarm LEDs	Dark on: Reflected light is insufficient Far on: Detected distance > maximum	Bright on: Reflected light is excessive Near on: Detected distance < minimum	
Calculation Over LED	On: Analog output (calculated) exceeds output range, MX1B only		
Alarm Input LED	On: When alarm input turns on, MX1B only (when using two units together)		
Power LED (on both amplifier and sensor head)	Green LED when power is on Orange LED when a laser is emitted during normal operation Laser beam emitted approximately 10 seconds after power-up; laser emission can be controlled while the power is on, using remote interlock provided		
Temperature Drift	±2 mV per °C (maximum)		
Frequency	11.3KHz		
Hysteresis	Selectable: Narrow (N) = 40 mV or wide (W) = 200 mV		
Light Source	Laser diode (780 nm)		
Receiving Element	PSD (position sensitive device)		



1. These specifications were developed from tests using a white ceramic object at the reference sensing distance, using the normal response speed at (20ms) 25°C.
2. * Peak to peak of analog output noise.

Applications

Checking for warped boards

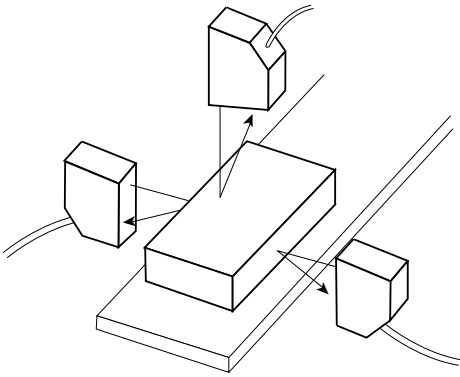
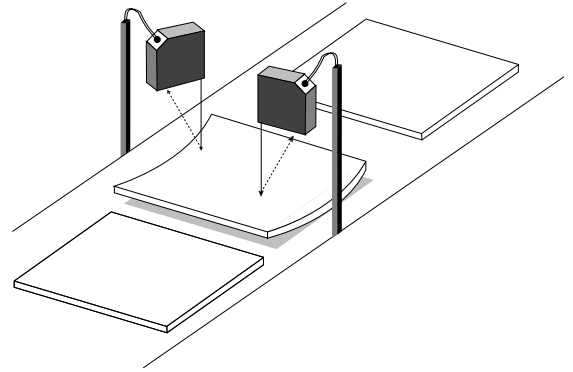

Detecting the height and width of wood or blocks

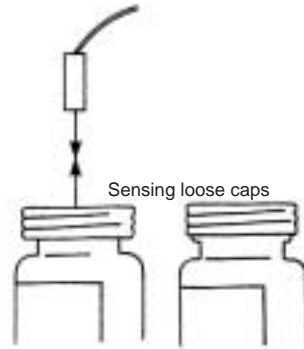

Sensing loose caps

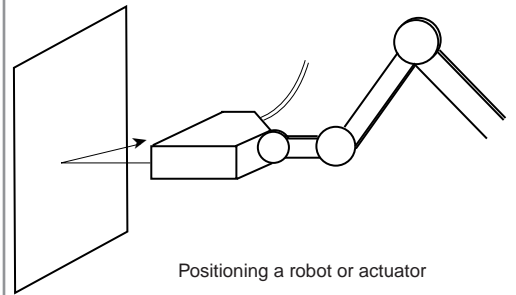

Positioning a robot or actuator

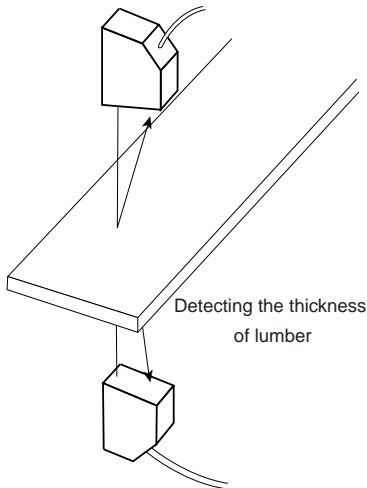

Detecting the thickness of lumber

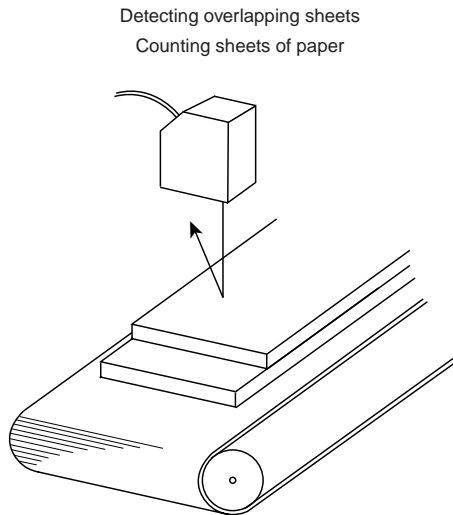

Detecting overlapping sheets
Counting sheets of paper

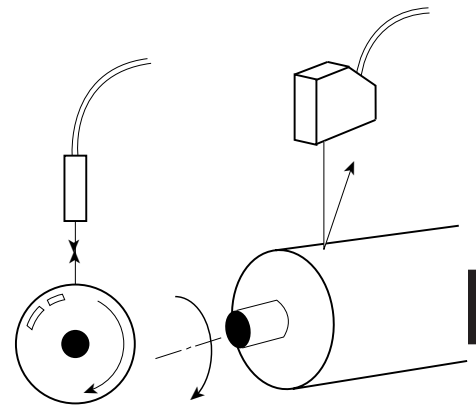

Sensing the roundness of a roller

Dimensions

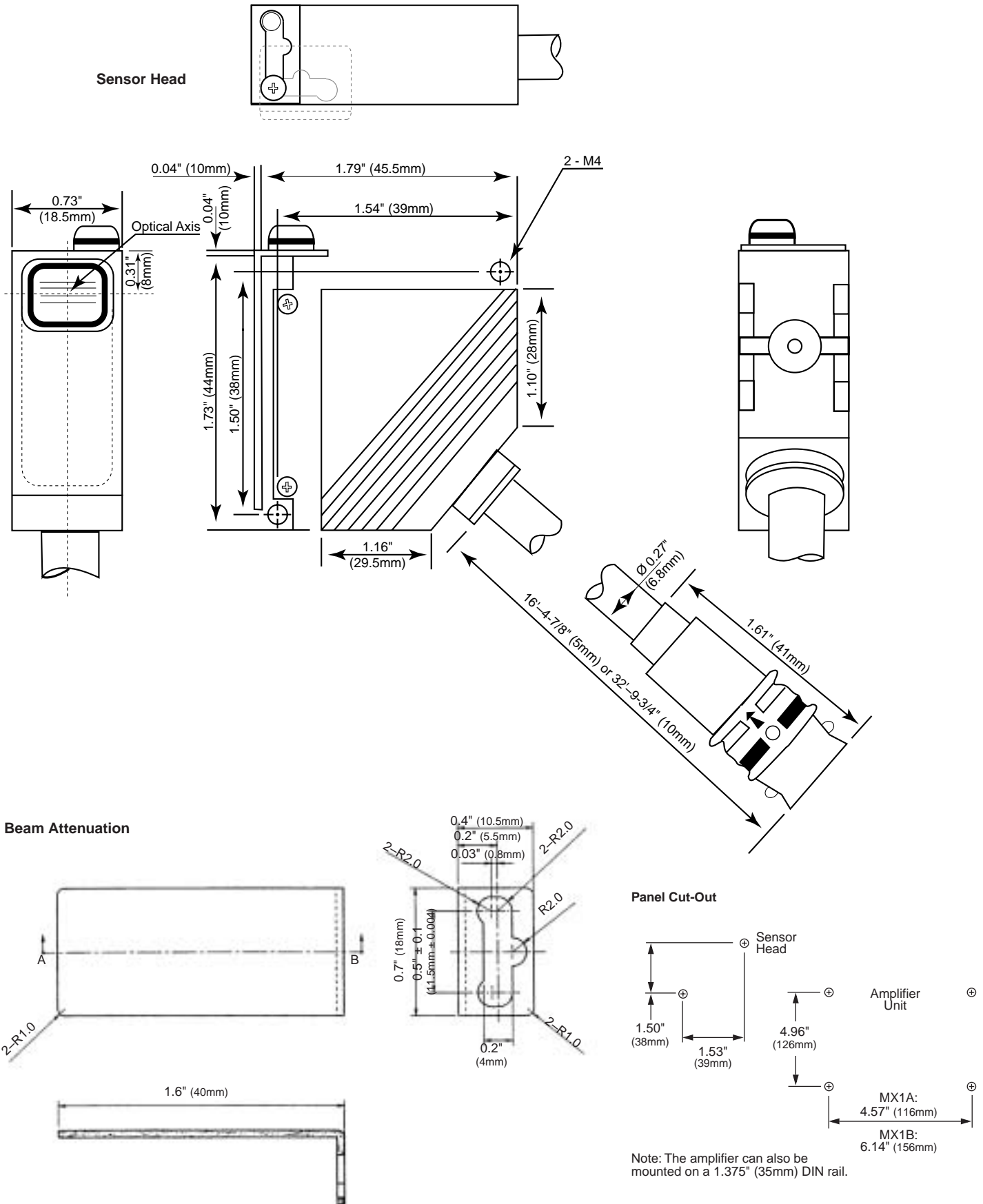

Dimensions, continued

MX1A Amplifier Unit

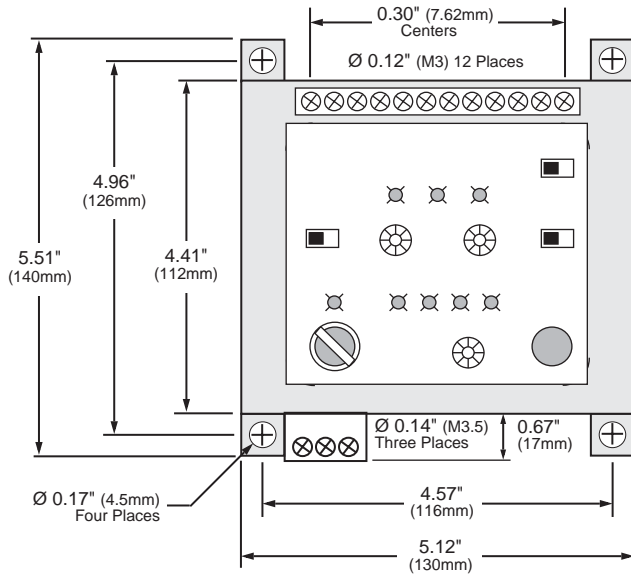

MX1B Amplifier Unit

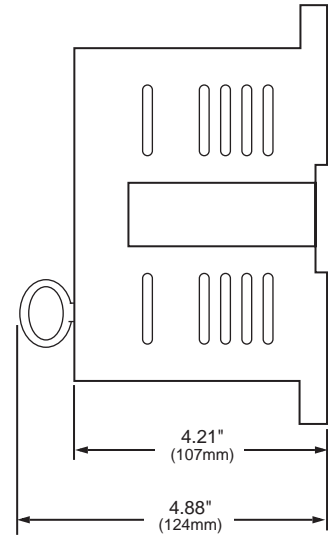
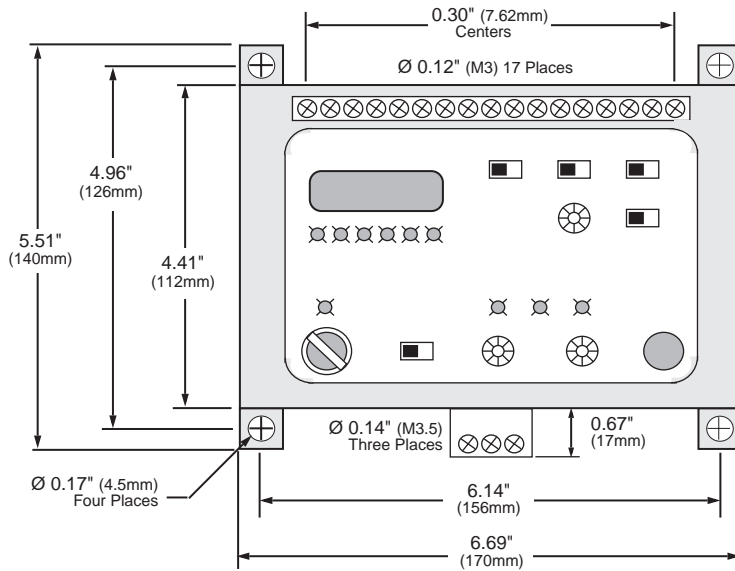

Side View
Typical for
MX1A and
MX1B

Laser Safety Information

Installation: If a sensor is installed so that the laser beam may shine or reflect into the eyes of a person passing by or working in the vicinity, place an opaque sheet of material in front of the beam to prevent potential eye injury. For people working near a laser sensor, protective glasses which screen out a significant amount of the harmful radiation are recommended at all times.

All laser sensors also include a remote interlock terminal which can be used to turn the laser on or off with an external switch, as required, to operate the sensor safely from a remote location. As required by law for all class IIIb lasers, the MX1A and MX1B sensors feature a safety key switch. For the MX1A and MX1B, an LED indicator is lit (green) upon laser transmission; 10 seconds later the LED changes color (amber) when the laser beam turns on.

To avoid exposure to harmful radiation, never disassemble a laser sensor.

WARNING: Do not allow class IIIa and IIIb laser beams to shine directly into the eyes. Do not allow lasers to reflect from a glossy, shiny, or reflective surface into the eyes.



Labelling: IDEC laser sensors include **CDRH-approved** safety warnings shown on the right and below, in compliance with federal regulations of the **Center for Devices and Radiological Health**.



MX1C Miniature Laser Sensor:
Class IIIa Laser (670nm) Visible Beam



MX1A and MX1B Laser Sensors:
Class IIIb Laser (780nm) Invisible Beam



All Laser Sensors:
Identification and Certification

mfd.: **FEBRUARY 1997**
Product conforms to
21 CFR 1040

MX1A/B Invisible Laser:
Aperture Warning



MX1C Visible Laser:
Aperture Warning

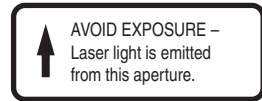

General Information

Specifications

Do not operate a sensor under any conditions exceeding these specifications.

Do not operate a sensor under current and voltage conditions other than those for which the individual sensor is rated.

Do not exceed the recommended operating temperature and humidity. Although sensors are rated for operation below 0°C, this specification does not imply that performance characteristics will remain constant under prolonged freezing conditions. Continued exposure and the accompanying frost, ice, dew, and condensation which accumulate on the optical surface will adversely affect sensor performance.

To maintain superior performance characteristics, do not exceed vibration and shock resistance ratings while operating a sensor. In addition, avoid isolated impacts to the sensor housing which are severe enough to adversely affect the waterproof characteristics.

IEC (International Electrotechnical Commission) Ratings

Sensors rated IP67 are resistant to moisture when occasionally immersed in still water. Sensors rated IP64 through IP66 are resistant to moisture when occasionally subjected to splashing or when located in the vicinity of turbulent waters. These ratings do not imply that a sensor is intended for use under continual high-pressure water spray. Avoid such applications to maintain optimal sensor performance.

Sensors rated IP64 through IP67 are dust-tight and water-tight. For best performance, avoid using any sensor in an area where it will be subjected to heavy particle blasts and where dust, water, or steam will accumulate on the optical surface.

Start-up

Do not test the housing for dielectric strength and insulation resistance, since the housing is connected to the electronic circuit ground of a sensor. Do not perform dielectric strength and insulation resistance tests on electrical systems without disconnecting photoelectric sensors, as such testing may result in damage to the sensor.

Several lines of sensors, as noted in the individual *operation* sections, are provided with an internal circuit to turn an output off for a specified amount of time upon power-up. This delay is normal; it prevents a transient state when turning power on.

Optimum Performance

The optical surface of each sensor must be cleaned on a regular basis for continual superior performance. Use a soft cloth dipped in isopropyl alcohol to remove dust and moisture build-up.

IMPORTANT: Do not use organic solvents (such as thinner, ammonia, caustic soda, or benzene) to clean any part of a sensor.

All sensors experience signal inconsistencies under the influence of inductive noise. Do not use sensors in close proximity to transformers, large inductive motors, or generators. Avoid using sensors in direct contact with sources of excessive heat. Also avoid operation in close proximity to welding equipment.



1. Even though the SA6A ultrasonic sensor features protection against noise, there may be adverse effects from strong noise.
2. It is strongly recommended to avoid using any sensor where it will be continually subjected to elements which impair performance or cause corrosive damage to the sensor. In particular, avoid strong vibrations and shocks, corrosive gases, oils, and chemicals, as well as blasts of water, steam, dust, or other particles.

Extraneous Light

Bright, extraneous light such as sunlight, incandescent lights, or fluorescent lights may impair the performance of sensors in detecting color or light.



3. SA6A ultrasonic sensors are not affected by extraneous light.

Make sure that extraneous light does not exceed recommended levels found in the individual *specifications* sections. When 500 lux is specified, this is equal to 50 footcandles. The average factory illumination is ordinarily below this level, except in areas where visual inspection is being performed. Only in such brightly lit areas is incident light of particular concern.

Unwanted light interference can often be avoided simply by making sure that the optical receiver is not aimed directly toward a strong light source. When mounting direction cannot be adjusted, place a light barrier between all nearby light sources and the receiver.

Reflected-Light Sensors

When installing sensors which detect reflected light, make sure that unwanted light reflections from nearby surfaces, such as the floor, walls, reflective machinery, or stainless steel, do not reach the optical receiver.

Also, make sure that reflected-light sensors mounted in close proximity do not cause interfering reflections. When it is not possible to maintain the recommended clearance between sensors, as noted in the individual *installation* sections, provide light barriers between sensors.

Through-Beam Sensors

A slit attachment is available to modify the beam size of through-beam sensors. This option is recommended for detecting very small objects (near the size of the smallest object which a sensor can detect) or for eliminating light interference when sensors are mounted in close proximity.

Laser Sensors

IMPORTANT: Always consider safety when installing a laser sensor of any kind. Make sure that the laser beam cannot inadvertently shine into the eyes of people passing by or working in the vicinity. See safety information on page Q-20.

Mounting

The mounting bracket and hardware are included with sensors, where applicable. Use the appropriate hardware for mounting, along with washers and spring washers or lock nuts. Do not overtighten attachment hardware. Overtightening causes damage to the housing and will adversely affect the waterproof characteristics of the sensor.

Best results can be obtained when the sensor is mounted so that the object sensed is in the center of the beam, rather than when the object is located near the edges of the sensing window. In addition, the most reliable sensing occurs when the majority of the objects being sensed are well within the sensing range, rather than at the extreme near and far limits.

Wiring

Avoid running high-voltages or power lines in the same conduit with sensor signal lines. This prevents inaccurate results or damage from induced noise. Use a separate conduit when the influence of power lines or electromagnetic equipment may occur, particularly when the distance of the wiring is extended.

IMPORTANT: Connect the sensor cables and wires as noted in the individual *Wiring* sections. Failure to connect as shown in wiring diagrams will result in damage to the internal circuit.

When extending sensor cables and wires, make sure to use cables equal or superior to that recommended in the individual *specifications* sections.

When wiring terminals, be sure to prevent contact between adjoining terminals. When using ring or fork lug terminals, use the insulated sleeve style only. Each sensor terminal can accept only one ring of fork lug terminal.

On ISF series photoelectric sensors, use recommended cable, along with the attached packing gland and washer, when wiring the terminals. This ensures waterproof and dustproof characteristics.

Power Supply

Noise resistance characteristics are improved when a sensor is grounded to the 0V power terminal. If the 0V power terminal is not at ground potential, use a ceramic 0.01µF capacitor which can withstand 250V AC minimum.

When using a switching power supply, be sure to ground the FG terminal to eliminate high-frequency noise. The power supply should include an insulating transformer, not an autotransformer.

On ISF series photoelectric sensors, the power supply should be sized according to the voltage drop through the lead wire when using a long extension for the DC type (328' or 100m maximum extension).

Power Supply

The compact PS5R-A power supply is the perfect companion item for most IDEC sensors. This power supply is only 1.77" (45mm) wide, 3.15" (80mm) tall, and 2.76" (70mm) deep. Call an IDEC representative for more details.

Part Number	Output Ratings
PS5R-A12	12V DC, 0.62A
PS5R-A24	24V DC, 0.32A

Miscellaneous

Strong magnetic fields may detract from the accuracy of the sensing measurement. Avoid mounting a sensor directly to machinery, since the housing is connected to the electronic circuit ground of the sensor. If it is necessary to mount a sensor on machinery, use the insulating plate and sleeve provided.

Glossary

Attenuation: Reduction of beam intensity as a result of environmental factors such as dust, humidity, steam, etc.

Dark on: Output energized when light is *not* detected by the receiving element. For through-beam sensors, light from the projector is not detected by the receiver when an object is present. For reflected light sensors, light is not detected when it is not reflected from an object surface.

Diffuse-reflected light sensors: Sensors that detect all scattered, reflected light. Light reflected from nearby surfaces, as well as intended object surface, is detected. Diffuse-reflected light sensors are often called "proximity switches," since they switch when any object is near. Also use to detect color contrast when colors reflect light intensity differently (green LED recommended for this application).

EEPROM: Acronym which stands for electronically erasable, programmable, read only memory.

Excess gain: Ratio of optical power available at a given projector-to-receiver range divided by the minimum optical power required to trigger the receiver.

Extraneous light: Incident light received by a sensor, unrelated to the presence or absence of object being detected. Extraneous light is usually unwanted background light such as sunlight and incandescent lamps in close proximity.

ΔE: The measurement of color difference as a three-variable function, located on an XYZ axis of light, hue, and chroma values.

Hysteresis: Operating point and release point at different levels. For solid state sensors, this is accomplished electrically. For mechanical switches, it results from storing potential energy before the transition occurs.

Light on: Output energized when light is detected by receiving element. For through-beam sensors, light from the projector is detected by the receiver when an object is not present. For reflected light sensors, light is detected when it is reflected from an object surface.

Linearity: Measurement of how nearly linear, that is, how accurate actual analog output is, with respect to distance.

NPN/PNP: Types of open collector transistors. NPN is a sink transistor; output on establishes negative potential difference. PNP is a source transistor; output on establishes positive potential difference.

Polarizing: Filtering out all reflected light except that which is projected in one plane only. Polarized retro-reflected light sensors detect the light from corner-cube type reflectors when an object is not present.

Reflected-light sensors: Sensors with the projector and receiver in one housing. Light is projected by the light source, and reflected light is received by the optical surface. Includes diffuse-reflected, retro-reflected, limited-reflected, and spot-reflected sensors.

Repeatability: Ability of a sensor to reproduce output readings consistently when the same value is applied consecutively, in the same direction, for a specified number of cycles, or for a specified time duration.

Resolution: Overall dimension of the smallest object which can be detected (when sensing the presence of an object) or smallest increment of distance which can be distinguished with reliable results (when sensing the position of an object).

Response time: Time elapsed between input and output. Total response time is the sum of object detection, amplifier response, and output response times.

Retro-reflective scan: This type of reflected light sensor uses a special reflector to return projected light when an object is not present. Sensor detects the presence of an object when the light is reflected differently.

Through-beam sensors: Sensors with a separate projector and receiver. The light source from the projector is detected by the receiver, except when an object is present.

Transient: Undesirable surge of current (many times larger than normal current) for a very short period, such as during the start-up of an inductive motor.