



# Replacement Parts

58-GT3

November 2003

Reversing Drum  
Controllers  
Class 58  
T3

INDEX	PART NO.	PCS. REQD.	NAME OF PART
1	D03887-001	1	Frame assembly complete with insulation
2	D10445-001	1	Frame insulation
3	D0632-013	2	Fingerboards, (left or right hand)
4	*D0925-004	6	Fingers complete w/ copper tips
5	D56164001	1	Rotor assembly consisting of: cam, shaft rotor contacts, inner and outer tubing and arc shields
6	D00103-038	1	Shaft
7	D09944-001	1	Cam
8	*D01633-002	1	Rotor contact
9	*D01633-004	1	Rotor contact
10	*D01633-006	1	Rotor contact
11	D35281-007	4	Rotor contact
12	D01858-017	3	Outer tubing
13	D01858-021	1	Outer tubing
14	D01858-027	1	Outer tubing
15	D00379-001	1	Arc shield
16	D00379-002	3	Arc shields
17	D08340-001	1	Top assembly complete w/ bushing
18	D17731-004	1	Lever
19	D00114-001	1	Red knob
20	D06196-010	1	Spacer
21	D06227-001	1	Index lever assembly
22	*D09953-001	1	Index spring

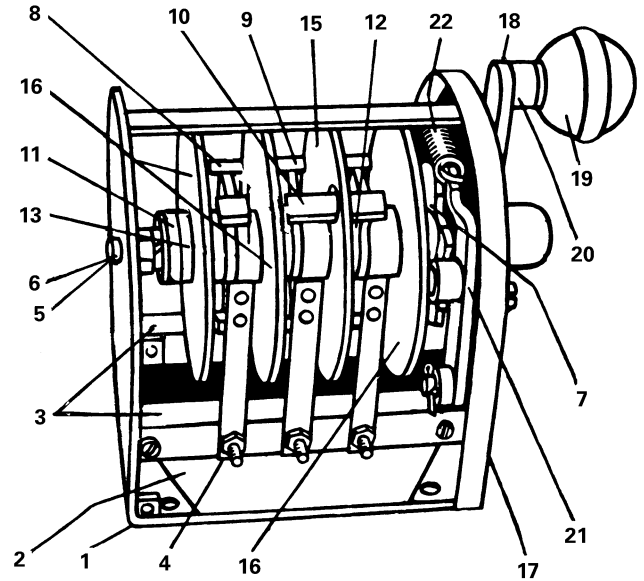

When ordering replacement parts, give style of switch and part number.

\* PK40 - Part Kit

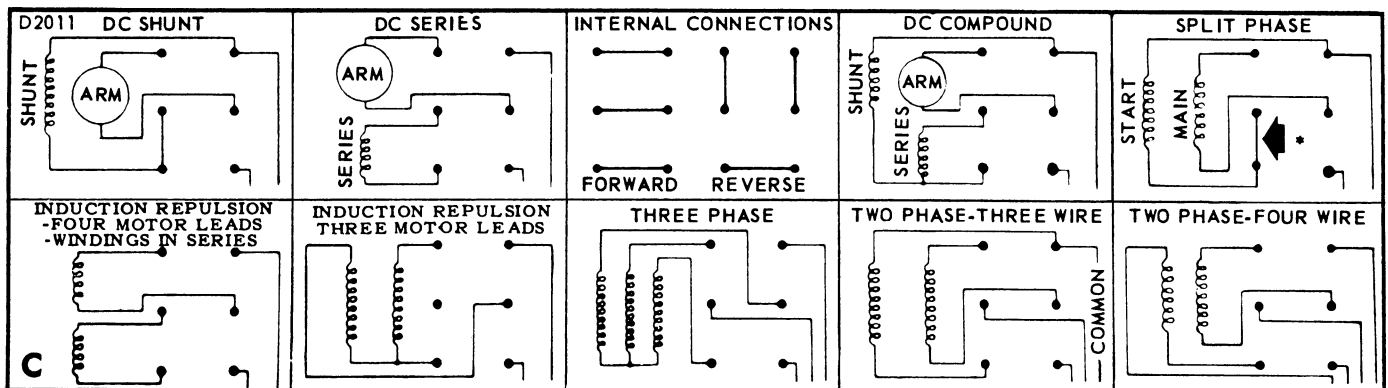

\* Add Jumper for Split Phase applications.  
When ordering replacement parts, give complete catalog number of switch and part number.

(For Engineering Reference Only - Rev. B)