



SERIES UH HOSE REELS

SINGLE HOSE GENERAL PURPOSE REEL

The Gleason U-Reel provides ultimate flexibility... larger diameter and/or wider spools, single or dual spring motors, chain drive where needed. In addition, the modular U-Reel design allows us to provide a custom reel for your application at the cost of an off-the-shelf unit. Sizing tables in this catalog enable you to choose your reel from a selection of commonly used sizes. Or, send us your requirements and let the sophisticated Gleason computerized program determine the spool size, spring configuration and drive that will give you the most rugged, smoothest operating and longest lasting reel money can buy.

The rugged U-Reel, featuring a heavy frame with spool supported on dual over-sized bearings, can easily handle air, water or hydraulic hoses up to 1.5" I.D. U-Reel is rated at 300 psi per standard hose and hose fittings but high pressure applications to 10,000 p.s.i. are possible with proper hardware. Options include an adjustable roller hose guide, spool lock, ratchet lock, 340° pivot base, dual hose and stainless steel fluid path.

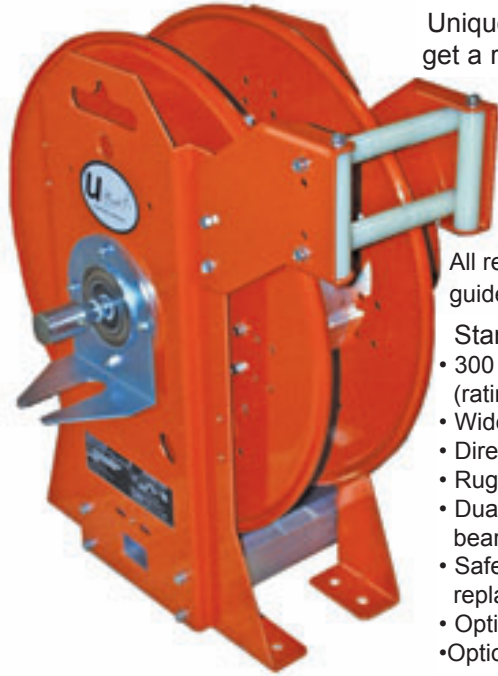

Unique Modular Design...You always get a reel that exactly fits your needs.

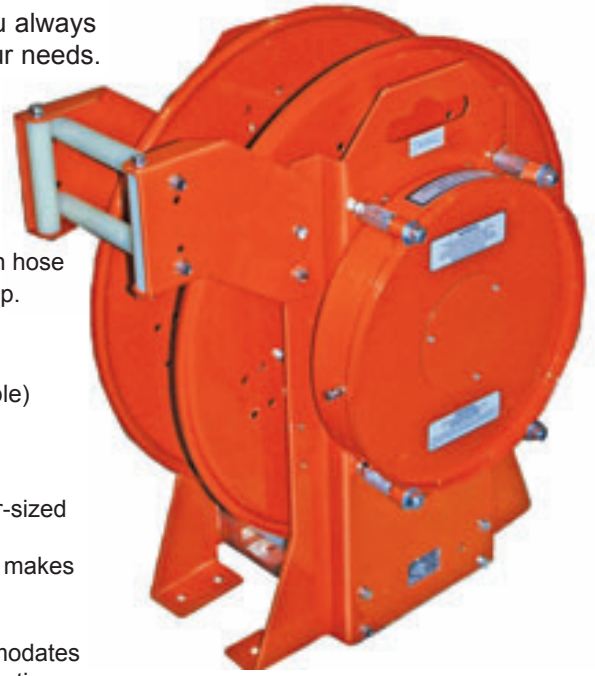

All reels feature a four position hose guide and adjustable hose stop.

Standard Features

- 300 PSI standard rating (ratings to 10,000 PSI available)
- Wide or Narrow spool
- Direct or Chain Drive.
- Rugged U-shaped frame
- Dual supported spool on over-sized bearings. Not cantilevered.
- Safetychange® Spring Motor makes replacement safe and easy.
- Optional 340° Pivot Base.
- Optional Roller Guide accommodates a variety of mounting configurations.
- Ratchet Lock

Air Hose Reels

HOSE (feet)	HOSE I.D.			
	3/4"	1"	1-1/4"	1-1/2"
50	UH21801-12-1008-1	UH24751-16-1208-1	UH281001-20-1410-4	UH321002-24-1610-1
60	UH21801-12-1008-1	UH241001-16-1208-1	UH281002-20-1410-1	UH321002-24-1610-1
70	UH24801-12-1008-1	UH28802-16-1208-2	UH281002-20-1410-1	UH321002-24-1610-1
80	UH24801-12-1008-1	UH28802-16-1208-2	consult factory	UH321002-24-1610-1
90	UH28802-12-1008-A-5	UH28802-16-1208-2	consult factory	consult factory
100	UH28802-12-1008-A-5	UH321002-16-1208-A-1	consult factory	consult factory

Liquid Hose Reels

HOSE (feet)	HOSE I.D.			
	3/4"	1"	1-1/4"	1-1/2"
50	UH21802-12-1008-1	UH241001-16-1208-2	UH281002-20-1410-2	consult factory
60	UH21801-12-1008-1	UH241002-16-1208-1	UH281002-20-1410-2	consult factory
70	UH24802-12-1008-1	UH28802-16-1208-2	consult factory	consult factory
80	UH24802-12-1008-1	consult factory	consult factory	consult factory
90	UH281002-12-1008-B-2	consult factory	consult factory	consult factory
100	UH281002-12-1008-B-2	consult factory	consult factory	consult factory

Lift Capacities based on speed of 150 ft/min. and acceleration of 0.50 ft/sec².

SERIES UH HOSE REEL DIMENSIONS

All dimensions in inches. For millimeters, multiply inches by 25.4

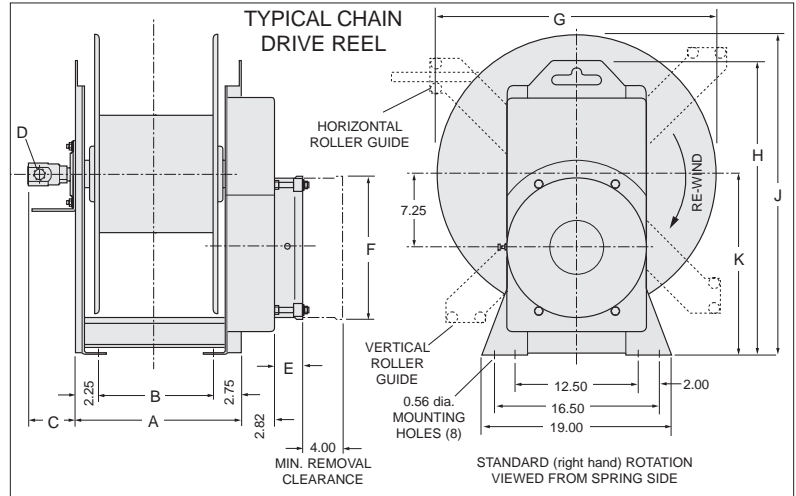
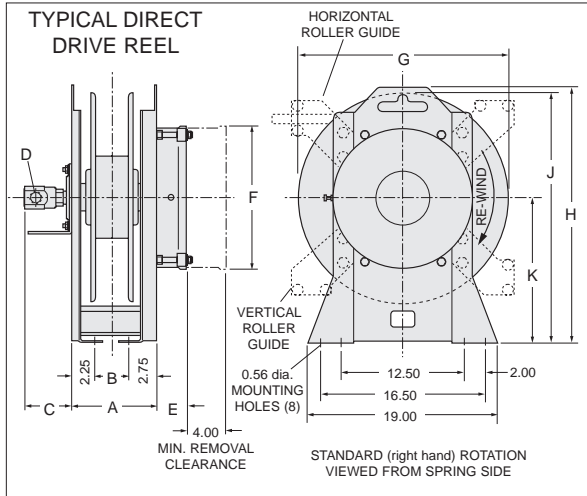

To find dimensions for the model reel you require, you must know:

- Spool Diameter and Width
- Hose I.D.
- Model of Spring(s)
- Quantity of Spring(s) in Motor
- Whether Reel is Direct Drive or Chain Drive

Find the dimensions for the known factors and plug them into the drawings above. Dimensions already on the drawings are the same for all models. All dimensions in inches. For millimeters, multiply inches by 25.4.

*Note: Total weight is sum of "X" and "Y" plus 55 lbs. if chain drive reel. All weights are in pounds. For Kg, multiply pounds by 0.45.

REEL WIDTH DIMENSIONS

SPOOL WIDTH	OVERALL FRAME "A"	MOUNTING HOLES "B"
6.00	10.50	5.50
8.00	12.50	7.50
10.00	14.50	9.50
12.00	16.50	11.50
14.00	18.50	13.50

OVERALL SIZE

SPOOL DIA. "G"	FRAME HEIGHT "H"	SPOOL HEIGHT "J"	SPOOL CENTER "K"	WEIGHT* "Y" lbs
18	24.25	22.00	13.00	84
21	25.75	25.00	14.50	91
24	27.25	28.00	16.00	100
28	29.25	32.00	18.00	115
32	31.25	36.00	20.00	140

HOSE SIZE DIMENSIONS

HOSE CODE	HOSE I.D.	SWIVEL "C"	"D"
06	3/8	3.00	3/8 NPT
08	1/2	3.12	1/2 NPT
12	3/4	3.25	3/4 NPT
16	1	4.12	1 NPT
20	1-1/4	4.38	1-1/4 NPT
24	1-1/2	6.50	1-1/2 NPT

SPRING MOTOR DIMENSIONS

MODEL SPRING	No. of SPRINGS	MOTOR WIDTH "E"	MOTOR DIAMETER "F"	WEIGHT* "Y" lbs
35	1	2.50	10.25	20
62	1	3.00	14.34	40
62	2	5.63	14.34	80
75	1	3.00	10.25	33
75	2	5.63	10.25	66
80	1	3.00	14.34	44
80	2	5.63	14.34	88
100	1	4.00	14.34	64
100	2	7.63	14.34	129

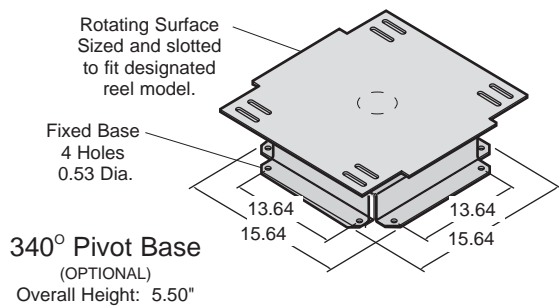

Gleason Reel Corp.
600 South Clark St. • P.O. Box 26
Mayville, WI 53050
Phone: 920-387-4120
Fax: 920-387-4189
www.hubbell-gleason.com