



# SERIES MH HOSE REELS

COMMERCIAL / INDUSTRIAL APPLICATIONS  
FOR MOBILE OUTDOOR ENVIRONMENT USE

Choose 1/4" dual welding hose, or 3/8" and 1/2" single hose in the Series MHA models or 1" and 1-1/2" hose in the Series MHB models. Full flow shaft and swivel assure maximum product delivery. Reels feature spring rewind and ratchet lock, multi-position four roller hose guide and adjustable hose stop. Rugged steel construction. Steel components protected by durable baked polyester finish. Because rigid plumbing to reel input is not advised, all reels include a convenient 3' long connecting hose. Male input fitting on connecting hose is the same size as output hose on reel spool.

### REELS FEATURE:

- 1/4", 3/8", 1/2", 1" or 1-1/2" hose
- air, water, oil, grease or oxy/acetylene duty
- Rugged steel construction
- High quality swivel joints designed with seals for each specific fluid application
- Hand pull, fully automatic rewind
- Heavy duty mounting brackets
- Spring motors are safety banded, totally enclosed and lubricated for long, trouble free performance
- Positive ratchet lock
- Multi-position adjustable full width hose guides to prevent hose from "stacking"
- Orange polyester baked-on finish
- Adjustable hose stops

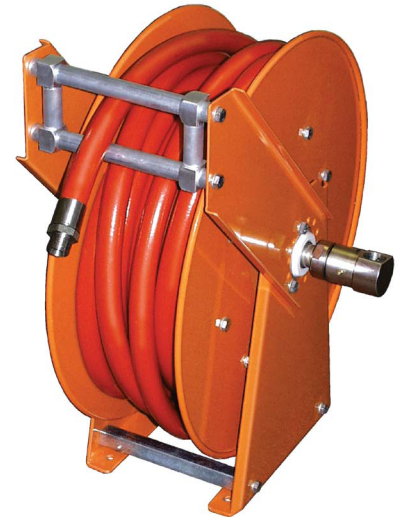

MODEL NUMBER	MAX PRESSURE psi	I.D. inch	O.D. inch	LENGTH feet	APPLICATION	SWIVEL MAT'L	HOSE MAT'L
MHA2550W	200 psi	1/4"	17/32"	50'	OXY/ACETYLENE	DUAL BRASS	EPDM RUBBER
MHA3850A	300 psi	3/8"	23/32"	50'	AIR/WATER	PLATED STEEL	EPDM RUBBER
MHA3850F	200 psi	3/8"	23/32"	50'	FUEL	STAINLESS STEEL	NITRILE/CSM
MHA3870F	200 psi	3/8"	23/32"	70'	FUEL	STAINLESS STEEL	NITRILE/CSM
MHA3850H	2000 psi	3/8"	11/16"	50'	OIL/HYD. FLUID	STAINLESS STEEL	SAE 100R1AT
MHA3870H	2000 psi	3/8"	11/16"	70'	OIL/HYD. FLUID	STAINLESS STEEL	SAE 100R1AT
MHA3850G	4000 psi	3/8"	47/64"	50'	GREASE	STAINLESS STEEL	SAE 100R2AT
MHA3870G	4000 psi	3/8"	47/64"	70'	GREASE	STAINLESS STEEL	SAE 100R2AT
MHA5050A	300 psi	1/2"	7/8"	50'	AIR/WATER	PLATED STEEL	EPDM RUBBER
MHA5050H	2000 psi	1/2"	53/64"	50'	OIL/HYD. FLUID	STAINLESS STEEL	SAE 100R1AT
MHA5050G	4000 psi	1/2"	55/64"	50'	GREASE	STAINLESS STEEL	SAE 100R2AT
MHB1050A	300 psi	1"	1-7/16"	50'	AIR/WATER	PLATED STEEL	EPDM RUBBER
MHB1070A	300 psi	1"	1-7/16"	70'	AIR/WATER	PLATED STEEL	EPDM RUBBER
MHB1050H	1000 psi	1"	1-13/32"	50'	OIL/HYD. FLUID	STAINLESS STEEL	SAE 100R1AT
MHB1070H	1000 psi	1"	1-13/32"	70'	OIL/HYD. FLUID	STAINLESS STEEL	SAE 100R1AT
MHB1550F	250 psi	1-1/2"	2-3/32"	50'	FUEL	STAINLESS STEEL	NITRILE/PVC

## SERIES MH HOSE REEL DIMENSIONS

All dimensions in inches. For millimeters, multiply inches by 25.4.

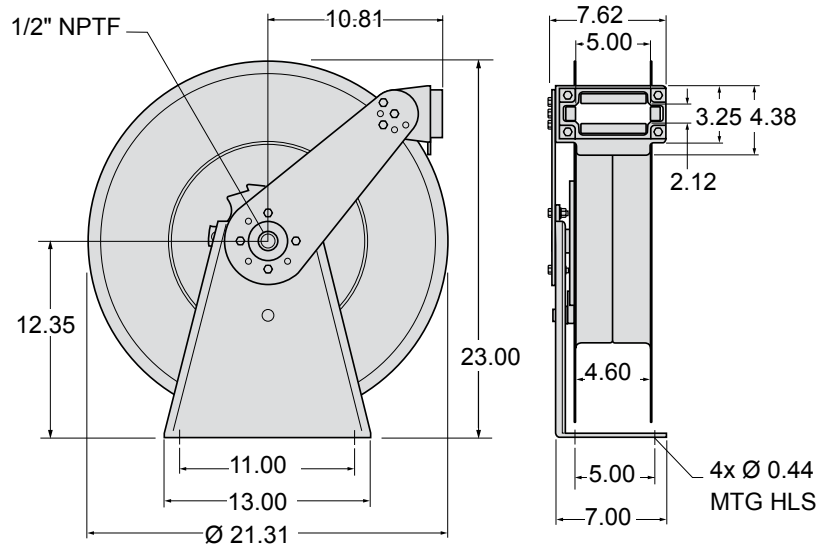

## SERIES MHA DIMENSIONS

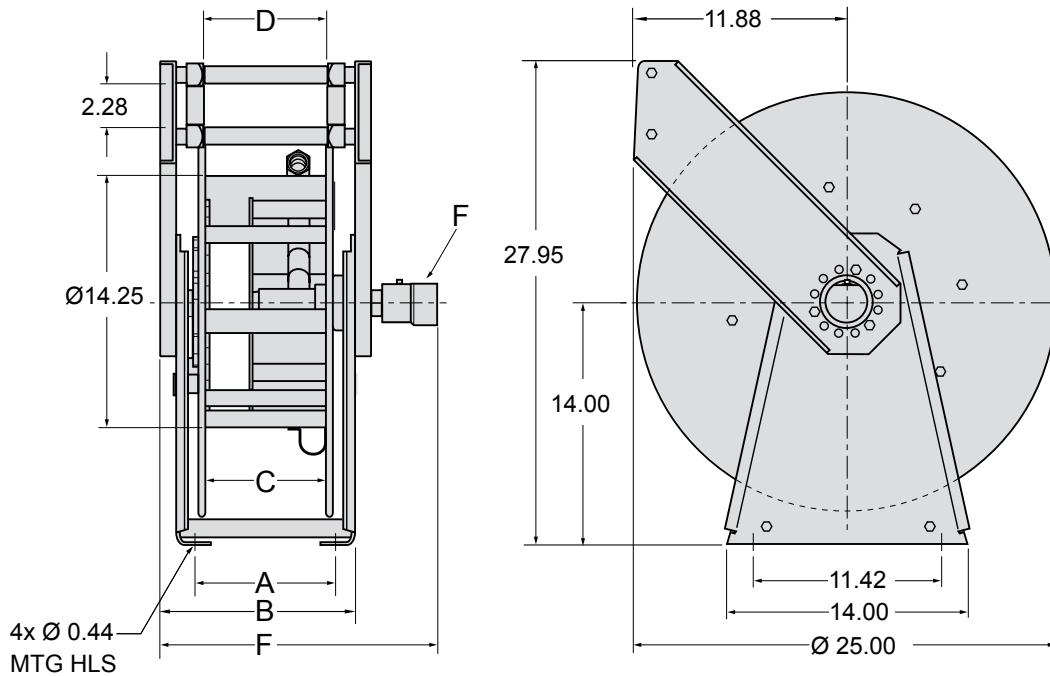

## SERIES MHB DIMENSIONS

A	B	C	D	E	F
7.83	10.28	7.89	6.73	16.00	1" NPTF
10.98	13.43	10.00	9.84	19.20	1-1/2" NPTF



## Gleason Reel Corp.

600 South Clark St. • P.O. Box 26

Mayville, WI 53050

Phone: 920-387-4120

Fax: 920-387-4189

www.hubbell-gleason.com