

OFFERS ENGINEERED PROTECTION FROM . . .

- **BROKEN DRIVE CHAINS**
- **VIBRATION**
- **LOOSE DRIVE CHAINS**
- **SHOCK DAMAGE**

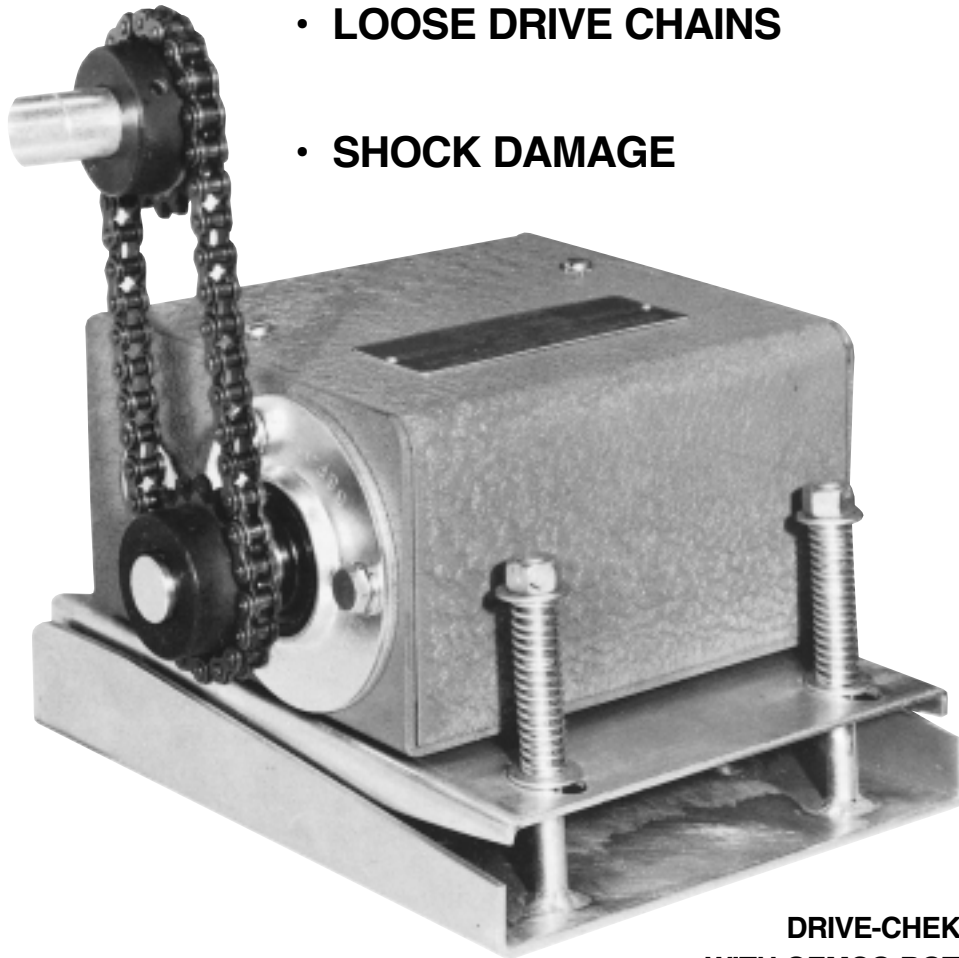

**DRIVE-CHEK  
WITH GEMCO ROTATING  
CAM LIMIT SWITCH**

## DESCRIPTION

The **DRIVE-CHEK** is a multi-purpose sub base that is mounted under a chain or belt driven mechanism. The unit serves three purposes; namely, a broken chain or belt detector, a chain or belt tightener, and a shock and vibration isolator.

A Gemco Indicator Switch is provided with each **DRIVE-CHEK** Unit to indicate when a drive belt or chain failure has occurred. Shock and vibration from the machine to the hinge plate of the **DRIVE-CHEK** Unit are dampened by coil springs on one end of the hinge plate and an elastomeric support on the other end.

The springs also maintain a constant tension in the drive belt or chain. **DRIVE-CHEK** is of rugged welded construction and is painted to prevent corrosion. The drive chain or belt can be attached to the mechanism being driven from either above or below the **DRIVE-CHEK** base.

The mounting and set up procedures for the **DRIVE-CHEK** Indicator Switch and the location of the coil springs are outlined on pages 4 and 5.

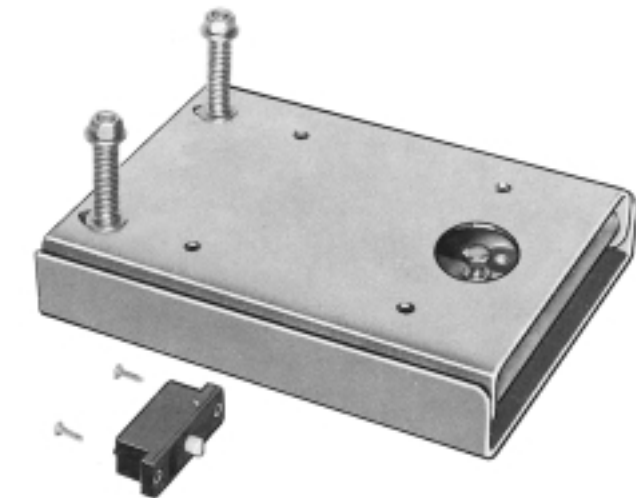

## DRIVE-CHEK INDICATOR SWITCH

### Function and Installation

A Gemco single pole double throw switch with mounting plate is supplied with each **DRIVE-CHEK** Unit and can be easily mounted inside the Gemco Rotating Cam Limit Switch enclosure. A Gemco double pole double throw switch can also be supplied at additional cost.

Three holes are drilled in the base of the Rotating Cam Limit Switch (see pages 6 and 7 for size and location) to mount the **DRIVE-CHEK** Indicator Switch. After the unit is mounted on the machine with the Rotating Cam Limit Switch and drive chain in place, the two coil springs between the stationary and movable part of the unit will be compressed to nearly their solid height.

The indicator switch is then adjusted to be engaged. If the chain breaks or runs off its sprockets, the coil springs will raise the hinge plate and the indicator switch will be disengaged (when the drive is below the hinge plate). The switch would be wired into the control circuit of the machine drive to stop the machine.

When ordering the **DRIVE-CHEK** Unit with the Gemco Rotating Cam Limit Switch, there will not be any additional charge for drilling the holes in the Rotating Cam Limit Switch enclosure for the Gemco Indicator Switch.

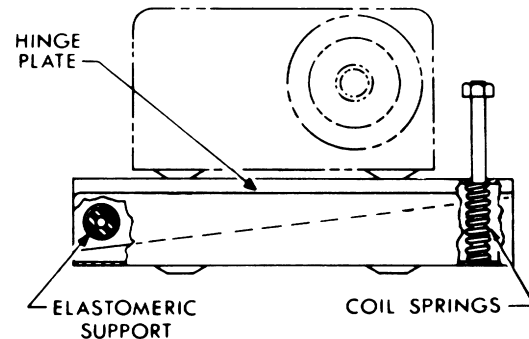

Figure 1

## DRIVE-CHEK for Gemco Catalog Section 1980 Rotating Cam Limit Switches\*

No. of Circuits	1980 NEMA 1	1980 NEMA 4 and 12
	Catalog Number	Catalog Number
2 - 4	1970-104	1970-1204
5 - 6	1970-106	1970-1206
7 - 8	1970-108	1970-1208
9 - 12	1970-112	1970-1212
13 - 16	1970-116	1970-1216
17 - 20	1970-120	1970-1220
21 - 24	1970-124	1970-1224

Addition Replacement indicator switch  
S.P.D.T. Cat. No. 1950-1404  
D.P.D.T. Cat. No. 1950-1405

## MOUNTING and SET-UP for GEMCO DRIVE-CHEK with DRIVE CHAIN UNIT

1. Align Drive Sprockets and mount **DRIVE-CHEK** base using 5/16" bolts.
2. Engage proper length drive chain to allow hinge plate to be parallel to the base when drive chain is tight.
3. Attach flexible conduit to allow free movement of the hinge plate.
4. Set switch adjustment bolt to engage indicator switch if the drive chain breaks.
5. Tighten adjustment bolt locknut.
6. Assemble springs with washers on each end of the coil springs and self-locking nuts. The springs should be compressed to nearly solid height.
7. Check the movement of the hinge plate to insure that the conduit and chain guard does not restrict the hinge plate from tripping the **DRIVE-CHEK** Indicator Switch.

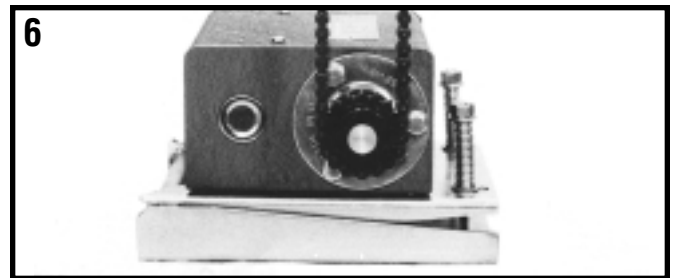
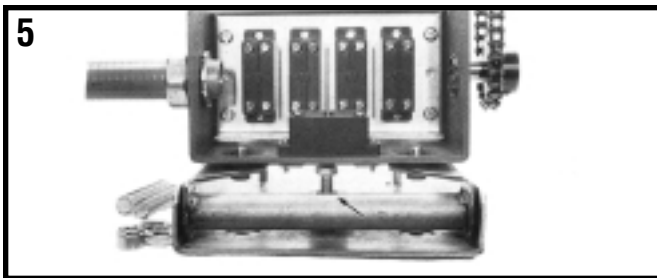
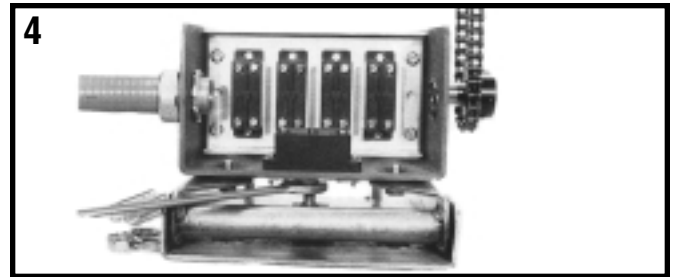
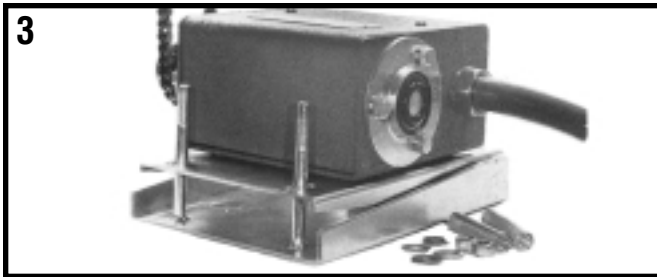
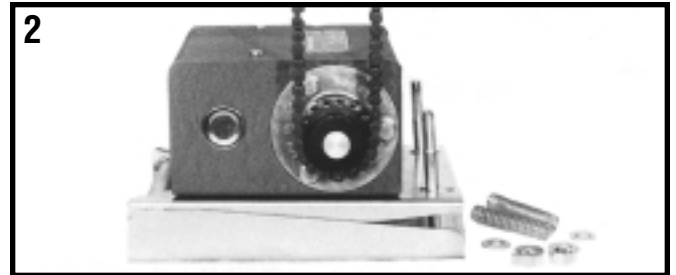
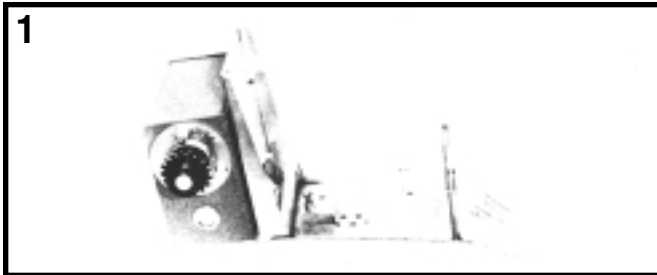

### INDICATOR SWITCH CONTACT ARRANGEMENT

Chain Engaged

Chain Broken

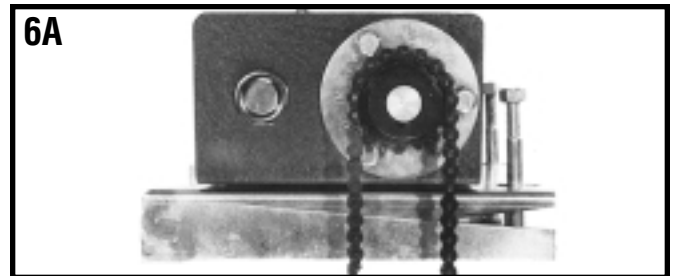
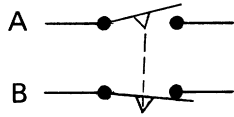
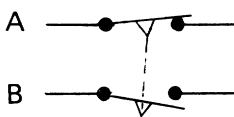

6A - Drive chain below is the same procedure to install

# DRIVE-CHEK DIMENSIONS FOR SERIES 1980

## NEMA 1 NEMA 4 and 12

Nema 1 1980 Series R.C.L.S. with Right Hand Shaft Mounted to Drive Chek.

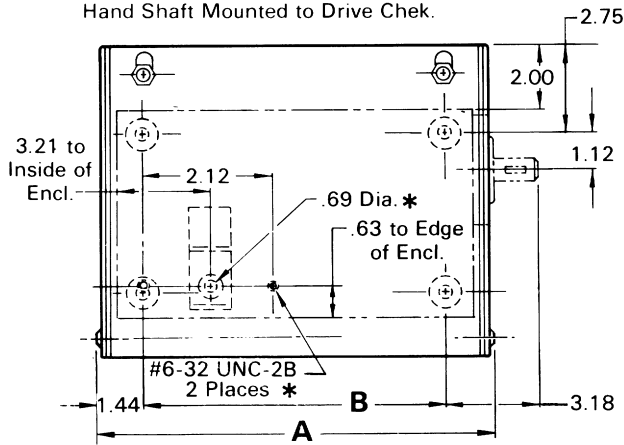

1980 Nema 4 and 12 or 1981 Nema 1, 4 and 12 R.C.L.S. with Right hand Shaft Mounted to Drive-Chek.

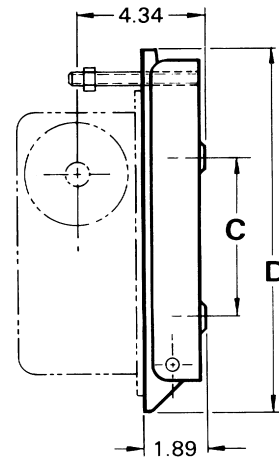
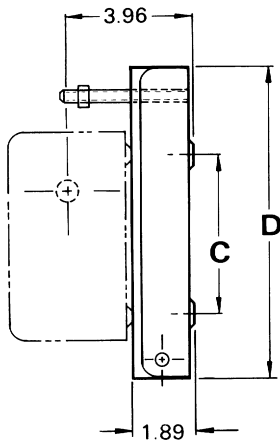
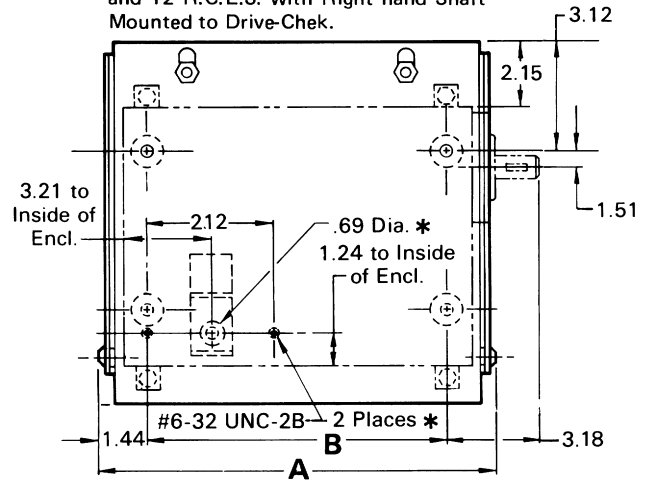

Dimensions shown apply when platform and base are parallel.

NO. OF CIRCUITS	A	B	C	D
2-4	7.31	4.42	5.00	9.75
5-6	9.75	6.86	5.00	9.75
7-8	12.19	9.30	5.00	9.75
9-12	17.07	14.18	5.00	9.75
13-16	23.48	20.60	5.50	10.25
17-20	28.36	25.48	5.50	10.25
21-24	33.24	30.36	5.50	10.25

NO. OF CIRCUITS	A	B	C	D
2-4	7.31	4.42	5.00	11.40
5-6	9.75	6.86	5.00	11.40
7-8	12.19	9.30	5.00	11.40
9-12	17.07	14.18	5.00	11.40
13-16	23.48	21.62	7.00	13.40
17-20	28.36	26.50	7.00	13.40
21-24	33.24	31.38	7.00	13.40

# AMETEK®

## PATRIOT SENSORS

1080 NORTH CROOKS ROAD • CLAWSON, MI 48017 USA  
 800-635-0289 • 248-435-0700 • Fax 248-435-8120  
[www.patriotsensors.com](http://www.patriotsensors.com) • [www.ametek.com](http://www.ametek.com)

1970.C1  
4/99 • Z26  
1M