



# Replacement Parts

58-GJ5

November 2003

Reversing Drum Controller  
Class 58  
J5

ITEM NO	NAME OF PART	PCS REQD	PART NO
	Rotor Assembly, complete with Spindle, Cam, Rotor Sleeves, Outer Tubing, Arc Shields and Spacers, and Contacts.	1	D27960012
1	Radial Handle (Plastic Molded)	1	D55711001
2	Top	1	D08592001
3	*Spring	1	D00985002
4	*Lever & Roller Assembly	1	D10288001
5	Outer Tubing	1	D08980017
6	Arc Shield	3	D08945001
7	Contact Shield	2	D09129001
8	*Rotor Contact	1	D03275001
9	Rotor Sleeve	1	D09369001
10	Arc Shield	1	D08945005
11	Rotor Sleeve	1	D09369001
12	*Fingers	6	D13831001
13	*Rotor Contact	1	D03275002
14	Rotor Sleeve	1	D09369001
15	*Rotor Contact	1	D03275006
16	Fingerboards (RH & LH)	2	D08959001
17	Frame Insulation	2	D08795001
18	Outer Tubing Rotor Shaft	1 1	D08980020 D08777001
	Parts Kit - Includes all items marked by asterisk(*).		PK21
	Cover assembly		D08964002

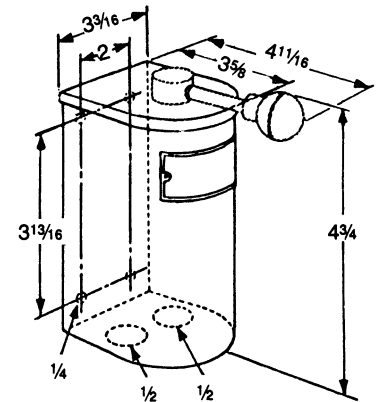
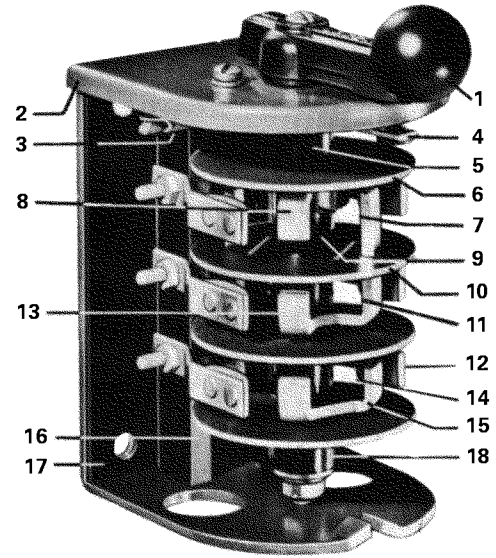

## CONNECTION DIAGRAMS Top Of Diagram Is Handle End

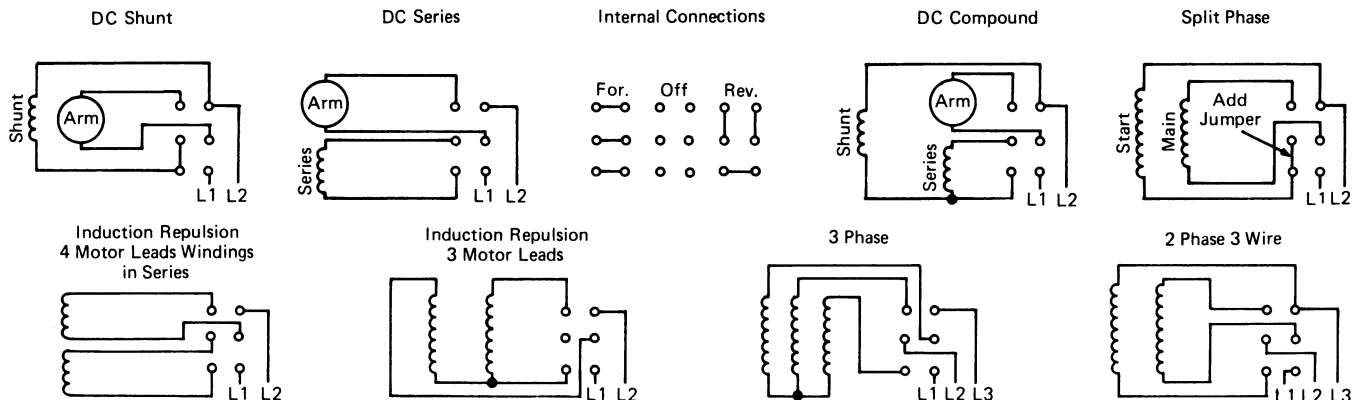

(For Engineering Reference Only - Rev. D)