

# FV2 Brushless Digital Feedback

- Bidirectional Frequency/Voltage or Frequency/Current Converter
- An FV2 and an encoder replace a DC Tachometer when precision feedback is required.



## APPLICATION/INDUSTRY

Dynapar FV2 frequency-to-voltage converter measures a digital pulse input frequency and converts it to an analog: 10 VDC or 4-20 mA output proportional to frequency/speed. When used with a Dynapar encoder it eliminates the need for a tachometer, and provides velocity feedback for closed loop speed control.

## DESCRIPTION

A wide range of digital pulse transducers, application speed ranges, and converter response times can be configured via front panel switches. The FV2 also includes 12 VDC transducer supply power.

A factory- or field-installed option board can provide these features:

- Optical isolation for analog outputs
- An auxiliary set of unidirectional or bidirectional digital outputs
- Relay outputs for signaling transducer phase failure or loss; direction reversal; over/underspeed detection

## FEATURES AND BENEFITS

- An FV2 and a Dynapar encoder is lower cost than a DC tachometer when precision feedback is required.
- No brushes to wear and replace.
- Because the FV2 is so versatile, it may eliminate the cost of additional transducers and their associated mounting expense.

### Electrical Features

- ±10 VDC or 4-20 mA analog output.
- Linearity is typically ±0.01% of full scale.
- Serves any variable speed drive application (single, double, or four quadrant drives).
- Switch selectable 115 or 230 VAC, 50/60 Hz power.
- Switch selectable response time (<10, <20, <36 or <46 msec.).
- Built-in transducer power supply.
- Plug-in terminal strips for field connections.

## SPECIFICATIONS

### STANDARD OPERATING CHARACTERISTICS

#### Electrical

Input Power Requirements: 115/230 VAC ±10%, 50/60 Hz; 120 mA @ 115 VAC, 60 mA @ 230 VAC

Available Power for the Transducer: 12 VDC ±5%, 200 mA max.

Input Signal: (Field-Selectable) 4 to 15V differential; or 8 to 15V single-ended; or magnetic 1.5 to 15V peak-to-peak

Input Frequency Range: (Field-Selectable)  
Bidirectional: 0-500 Hz to 0-100 kHz;  
Unidirectional: 0-1 kHz to 0-100 kHz;

Analog Output: ±10V bidirectional; 0-10V unidirectional @ 25 mA

Output Linearity: ±0.01% of span

Temperature Stability: ±0.02% per °F

Current Range: 4-20 mA

Current Linearity: ±0.2% max.

Compliance: +16V min.

Response Time: <10 msec. switch selectable to <20, <36, or <46 msec.

Output Ripple: Volts RMS is generally less than brush generators and is predictable depending on input frequency from an encoder. For 240 PPR, open loop ripple is 0.080V at 25 RPM, 0.03V at 250 RPM and 0.015V at 2500 RPM

Output Overrange: 10% min. (volt. or current)

Output Offset Adjustable

#### Environmental

Operating Temperature: 0 to 60°C

Storage Temperature: -18° to +85°C

Relative Humidity: to 90% non-condensing

### OPTIONAL FEATURES

The following features are available with the FV2 option board, which can be factory- or field-installed:

#### Auxiliary Isolated Digital Outputs

When supplied separately with 12VDC, an isolated digital differential line driver output is supplied corresponding to the A and B input phases. By connecting the analog power supply cable to the option board, the analog outputs can also be powered by the separate supply and optically isolated from the digital inputs.

#### Transducer Phase Reversal Detector

This feature monitors the A and B phases and detects reverse rotation. When reversal is detected, there is a user-selectable delay (2048 pulses max.) before the output relay drops out. The relay will not re-energize until: 1) the reset button is pressed, 2) an external reset signal is applied, or 3) power is removed and restored. An inhibit input is provided to override the reversal detection circuit.

#### Transducer Phase Failure Detector

This feature monitors the A and B phase inputs and detects a failure (i.e. one phase failed high or low). Its output is a normally-open relay contact which opens upon failure detection. This relay contact is shared with a Phase Loss Detection circuit.

#### Transducer Phase Loss Detector

This feature monitors current supplied to the encoder and reacts to a decrease in current required. Failure is indicated by opening the relay contact shared with the Phase Failure Detector. Current trip level is field-adjustable. Transducer supply must be provided by FV2.

#### Zero Speed Detector

This feature monitors transducer speed, and can be set by the user to trip at a specific level corresponding to desired speed. A relay with a single-pole-double-throw contact is used for the output.

### SPECIFICATIONS FOR FV2 OPTIONS

#### Auxiliary Digital Outputs

Power Requirements: 12 ±3 VDC

Current Requirements: 25 mA w/ digital outputs only; 250 mA w/ analog outputs only

Outputs	Voltage Range	Sink (mA)	Source (mA)	Standard IC
Differential Line Driver	12 ±3 VDC	22	40	88C30

#### Transducer Reversal Detector

Forward Input Phasing: A leads B

Reversal Delay: 16, 32, 64, 128, 256, 512, 1024, or 2048 pulses, selectable.

Output: Relay contacts\*, latched upon failure. Latch Reset & Inhibit Input Requirements: TTL/CMOS, activates on high, 10K pull-down, 17V max.

#### Transducer Phase Failure Detector

Failure Type: A or B phase

Delay: 4 transitions

Output: N.O. contact\* shared with Phase Loss Detector

#### Transducer Phase Loss Detector

Current Level: 30 to 200 mA, adjustable

Output: N.O. contact\* shared with Phase Failure Detector

#### Zero Speed Detector

Adjustable Range: 10 Hz to 300 Hz

Response Time: Less than 0.1 sec.

Output: SPDT relay contact\*

\*Relay contacts are rated at (1) 1.0 amps, 24 VDC, or (2) 0.3 amps, 115 VDC resistive, or (3) 0.3 amps, 24 VDC, or (4) 0.2 amps, 115 VAC inductive.

ELECTRICAL CONNECTIONS

FV2-0 Functions		Terminal
Analog Outputs	4-20 mA	1
	Common	2
	±10V	3
Transducer Input & Supply	Signal B̄ (if used)	4
	Signal B (if used)	5
	Signal Ā (if used)	6
	Signal A or Magnetic	7
	Encoder Supply Common	8
	Encoder Supply V+	9
Power Input	115/230 VAC	L1
	115 Neutral/230 VAC	N/L2
	Case Ground	GND
FV2-1 Optional Functions		Terminal
Isolated Supply	Common	18
	Power	17
Transducer Auxiliary Outputs	A	16
	A	15
	B	14
	B	13
Transducer Phase Loss or Phase Failure	N.O.	12
		11
Zero Speed Detector	N.O.	10
		9
Reversal Detector Outputs	N.O.	8
	Common	7
	N.C.	6
	N.O. or N.C.*	5*
	Common	4
Reversal Detector Inputs	Reset	3
	Common	2
	Inhibit	1

\*Circuit is field-selectable as N.O. or N.C. contact with internal jumper.

APPLICATION CONSIDERATIONS

**Transducer Selection:** The FV2 operates on the frequency content of a sinusoidal, triangular, or square waveform. Typical transducers include:

- 1) A magnetic pick-up detecting a passing keyway, gear teeth, etc.
- 2) A photo eye which scans alternating opaque and transparent slots.
- 3) A digital tachometer or encoder.

For fast response of FV2 outputs, it is important that the transducer be located toward the high speed end of the drive train. For slow shaft speeds, the transducer must be capable of delivering a high number of cycles or pulses per revolution. The transducer should also be capable of delivering a usable output for the entire speed range through maximum speed. The following formula is convenient for relating machine speeds and sensor frequency output:

$$FRQ \text{ (CPS or Hz)} = \frac{RPM}{60} \times PPR$$

Where:

**RPM** is the speed of the shaft where the sensor is located in revolutions per minute.

**PPR** is the number of pulses (or cycles) produced by the sensor for one shaft revolution.

**FV2 Performance:** The FV2 range adjustment allows the unit to deliver full-scale output for any input frequency within the limits of each range rating. It will provide a better combination of fast response and low ripple when input frequencies for full scale output are at least 3 kHz and above. The FV2 is provided with the capability for field-installed capacitance to optimize response time vs. ripple if required (see the technical manual.)

Full-Scale Range Adjustment	Scaling Factor	
	Min.	Max.
50 – 100 kHz	÷ 4	
25 – 50 kHz	÷ 2	
12 – 25 kHz	x 1	
6 – 12 kHz	x 2	
1.5 – 6 kHz*	x 4	
3 – 6 kHz**	x 1	
1 – 3 kHz**	x 2	
0.5 – 1.5 kHz*	x 4	

\*Bidirectional inputs only  
\*\*Unidirectional inputs only

Typical Application

Bidirectional with 0 to ±10V Output

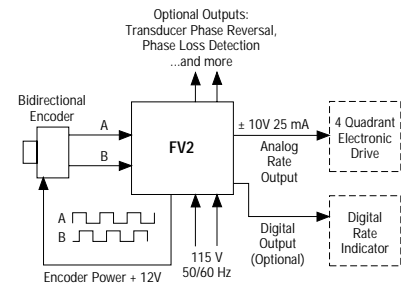

MOUNTING DIMENSIONS (INCHES/MM)

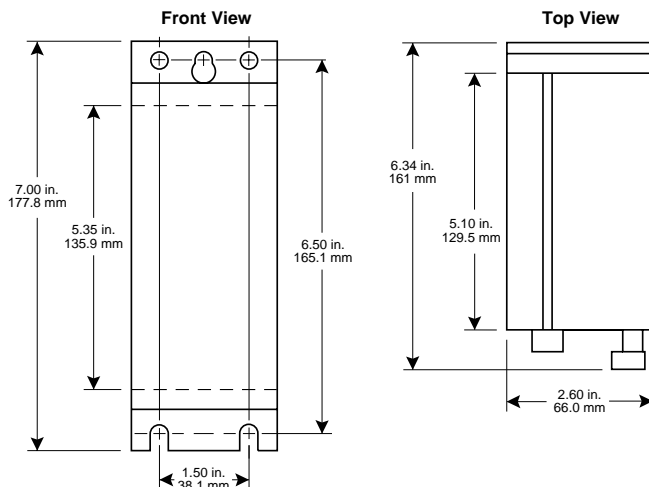

Ordering Information

Model No.	Description
FV2-0-S	Frequency-to-Voltage Converter
FV2-1-S	Same as FV2-0-S with Factory-Installed Option Board
FV2-N1	Option Board Only (Kit for Field Installation with FV2-0-S)
845-24*	Technical Manual

\*A technical manual is automatically included with each FV2 unit shipped. Use this publication number for ordering extra copies.

INCREMENTALS